

**MOUNTAIN IRON CITY COUNCIL MEETING
COMMUNITY CENTER
MOUNTAIN IRON ROOM
MONDAY, SEPTEMBER 16, 2013 - 6:30 P.M.
A G E N D A**

- I. Roll Call
- II. Consent Agenda
 - A. September 3, 2013, Regular Meeting (#1-17)
 - B. Receipts
 - C. Bills and Payroll
 - D. Communications (#65-68)
- III. Public Forum
- IV. Committee and Staff Reports
 - A. Mayor's Report
 - B. City Administrator's Report
 - 1. Campground Fixtures Quote (#18-23)
 - 2. Library Substitute Position (#24-25)
 - C. Public Works Director's Report
 - 1. Wire Quote (#26-27)
 - 2. Transformer Quote (#28-32)
 - 3. Safety Management Contract (#33-37)
 - 4. Tire Quotes (#38-39)
 - D. Sheriff's Department Report
 - 1. Monthly Statistics (#40)
 - E. City Engineer's Report
 - F. City Attorney's Report
 - G. Public Health and Safety Board
 - 1. Early Warning Sirens (#41-46)
 - H. Personnel Committee
 - 1. Lead Journeyman Lineman Position (#47-48)
 - I. Liaison Reports
- V. Unfinished Business
- VI. New Business
 - A. Resolution Number 35-13 Declaring Costs (#49-50)
 - B. Real Estate License Agreement (#51-64)
- VII. Communications (#65-68)
- VIII. Announcements
- IX. Adjourn

Page Number in Packet

MINUTES
MOUNTAIN IRON CITY COUNCIL
SEPTEMBER 3, 2013

Mayor Skalko called the City Council meeting to order at 6:30 p.m. with the following members present: Joe Prebeg, Jr., Susan Tuomela, Tony Zupancich, Alan Stanaway, and Mayor Gary Skalko. Also present were: Craig J. Wainio, City Administrator; Jill M. Clark, Municipal Services Secretary; Michael Downs, Director of Public Works; Rod Flannigan, City Engineer; Sally Peterangelo, Library Director/Special Events Director; and John Backman, Sergeant.

It was moved by Skalko and seconded by Tuomela that the consent agenda be approved as follows:

1. Add the following item to the agenda:
 - a. VI. I. Request to serve alcohol at the Community Center
 - b. Move Item IV.G. Planning & Zoning Commission to the first items on IV.
2. Approve the minutes of the August 19, 2013, regular meeting as submitted.
3. That the communications be accepted and placed on file and those requiring further action by the City Council be acted upon during their proper sequence on the agenda.
4. To acknowledge the receipts for the period August 16-31, 2013, totaling \$2,283,335.57, (a list is attached and made a part of these minutes).
5. To authorize the payments of the bills and payroll for the period August 16-31, 2013, totaling \$491,882.88, (a list is attached and made a part of these minutes).

The motion carried unanimously on a roll call vote.

During the public forum, Deneen Gunderson spoke regarding issues they were experiencing with the lot they purchased in South Forest Grove. She also asked what could be done to allow her husband to come to the City Hall without an escort. She also covered several issues with regard to their purchase of Lot 18 in South Forest Grove. She said that the cost for the electrical hook-up was more than they were advised when they purchased the lot, there were no street lights installed, the corner pin was missing from their lot, and the gas lines have not been put in yet.

Councilor Zupancich suggested that City Staff develop a welcome package for new residents moving in to Mountain Iron and for those that have purchased lots in the City owned additions.

Daniel Schultz, retired from Minnesota Power, now working for JDI Contracts Incorporated, said he was able to work with the Director of Public Works on the proposal for the substation.

At 6:53 p.m., it was moved by Zupancich and seconded by Tuomela to recess the regular meeting and open the public hearing on the vacation of Commerce Street and a portion of Park Ridge Drive pursuant to Minnesota Statute 412.851. The motion carried.

Councilor Zupancich said that this public hearing was for the relocation of County Road 102 for the new U. S. Steel entrance. He also said that there would be no City money spent on this road.

No one spoke during the public hearing and no communications were received.

At 6:54 p.m., it was moved by Zupancich and seconded by Tuomela to adjourn the public hearing and reconvene the regular meeting. The motion carried.

It was moved by Zupancich and seconded by Stanaway to accept the recommendation of the Planning and Zoning Commission and authorize the variance for Pentti Mahonen, 4929 Spirit Lake Road, Mountain Iron, parcel 175-0058-00080, for the installation of a septic system with a 75 foot setback from the lake. The motion carried unanimously.

It was moved by Stanaway and seconded by Tuomela to accept the recommendation of the Planning and Zoning Commission and authorize the variance for Ben and Marilyn West, 4919 Spirit Lake Road, Mountain Iron, parcel 175-0058-0090, for the installation of a septic system with a 75 foot setback from the lake. The motion carried unanimously.

The Mayor reported on the following:

- Condolences to the following families. Gladys Smith, Norman Niskanen, and George Teska.
- Fall Sports. He wished all the fall boys and girls sport activities a successful season.
- Sale of Lots. He advised the Council that another lot was sold in Unity Second Addition, making a total of 15 lots sold. He said that South Forest Grove has four lots sold.

It was moved by Prebeg and seconded by Zupancich to approve the agreement with the AEOA Energy Assistance Program, (a copy is attached and made a part of these minutes). The motion carried unanimously.

It was moved by Stanaway and seconded by Tuomela to accept the recommendation of the Public Health and Safety Board and begin condemnation proceedings for a residence at 5472 Bluebell Avenue, Mountain Iron. The motion carried unanimously.

It was moved by Zupancich and seconded by Tuomela to authorize the gas service agreement with Minnesota Energy Resources to install gas service to South Forest Grove with the cost not to exceed \$8,000. It was moved by Zupancich and seconded by Tuomela to amend the motion to include seeking reimbursement from the Economic Development Authority for the expenses. The amended motion carried unanimously on a roll call vote.

It was moved by Prebeg and seconded by Zupancich to award the quote for the hazardous substance removal and demolition of the following properties:

8863 Quartz Avenue
5681 Mineral Avenue
8786 Arbor Lane
5620 Falcon Avenue

to Grivette Environmental Management, LLC for the hazardous substance removal in the amount of \$12,000 and G-Men from Ely for the demolition for \$33,247. The motion carried unanimously on a roll call vote.

It was moved by Zupancich and seconded by Tuomela to approve the agreement with the Wisconsin Energy Conservation Corporation (WECC) to provide a residential Conservation Improvement Program (CIP) for the City of Mountain Iron. The motion carried unanimously.

It was moved by Prebeg and seconded by Tuomela to approve the bid for the construction of a substation, in accordance with the City's voltage modification plan and due to the relocation of County Road 102, to Minnesota Power in the amount of \$486,000. The motion carried unanimously on a roll call vote.

The Director of Public Works thanked Daniel Schultz for assisting with the planning and design of the voltage modification plan.

It was moved by Zupancich and seconded by Prebeg to direct Benchmark Engineering to proceed with the sanitary lift station study at a cost not to exceed \$11,869, plus reimbursable expenses not to exceed \$600. The motion carried unanimously on a roll call vote.

The Director of Public Works informed the Council that City Staff would begin installing the street lights in the South Forest Grove Addition now that houses were being constructed in the area.

The Library Director/Special Events Coordinator reported on the following:

- Monthly Report. She submitted her August, 2013 Library report to the Council.
- Winter Hours. She reminded everyone that the Library had now switched to their winter hours with the Library now closed on Fridays and open on Saturdays from 10 a.m. until 2 p.m.
- Pre-School Story Time. Would be starting soon.
- Tea on Tuesday. Would be starting soon.
- On-Line. They are starting an on-line book club.
- Old Pictures. City Staff has hung up some of the old antique pictures in the Library.
- Merritt Days. She submitted information regarding the celebration to the City Council. She said the event was a total success and she thanked the City for their support of the event.

It was moved by Prebeg and seconded by Tuomela to authorize payment request number one to Ulland Brothers Incorporated for the County Road 102 Utility Extension Project in the amount of \$293,444.84. The motion carried unanimously on a roll call vote.

It was moved by Stanaway and seconded by Tuomela to authorize payment request number one to Hibbing Excavating Incorporated for the Unity Drive Improvement Project in the amount of \$25,299.45. The motion carried unanimously on a roll call vote.

It was moved by Zupancich and seconded by Stanaway to authorize the first and final payment request to AAA Striping Service Company for the 2013 Striping Improvement Project in the amount of \$9,844.00. The motion carried unanimously on a roll call vote.

During the liaison reports, Councilor Zupancich, representing the Planning and Zoning Commission, informed the Council that a citation was issued, for a violation to the Zoning Ordinance, for operating a commercial business off of the Vern's Greenhouse property. The City is working with the individual to assist him in relocating.

It was moved by Prebeg and seconded by Zupancich to adopt Resolution Number 24-13, accepting work for the Bluebell and Daffodil paving project, (a copy is attached and made a part of these minutes). And further, to stipulate that the City Engineer work with Mesabi Bituminous to complete the necessary repairs. The motion carried unanimously.

It was moved by Zupancich to approve Resolution Number 30-13, vacating Commerce Street and part of Park Ridge Drive in the Rock Ridge Development. After further discussion, Zupancich withdrew his motion.

It was moved by Zupancich and seconded by Tuomela to table Resolution Number 30-13, vacating Commerce Street and part of Park Ridge Drive in the Rock Ridge Development. The motion carried.

It was moved by Zupancich and seconded by Tuomela to adopt Resolution Number 31-13, approving the proposed 2013 tax levy, collectable in 2014, representing a zero percent levy increase, (a copy is attached and made a part of these minutes). The motion carried unanimously.

It was moved by Prebeg and seconded by Stanaway to adopt Resolution Number 32-13, adopting the 2014 market rate based referendum levy for the General Obligation Community Center bonds and interest, (a copy is attached and made a part of these minutes). The motion carried unanimously.

It was moved by Zupancich and seconded by Tuomela to adopt Resolution Number 33-13, concerning the 2013 Economic Development Authority Tax Levy, (a copy is attached and made a part of these minutes). The motion carried unanimously.

It was moved by Zupancich and seconded by Tuomela to adopt Resolution Number 34-13, calling a hearing on proposed assessments for the County Road 7 Water Main Extension Project, (a copy is attached and made a part of these minutes). The motion carried unanimously.

It was moved by Zupancich and seconded by Tuomela to set a public hearing for Monday, December 2, 2013, at 6:30 p.m. for public input on the 2014 budget and levy. The motion carried unanimously.

It was moved by Zupancich and seconded by Stanaway to adopt the Master Road Agreement between the City, the Economic Development Authority, and U. S. Steel Corporation, as submitted. The motion carried unanimously.

It was moved by Prebeg and seconded by Tuomela to approve the release of access agreement between the City of Mountain Iron and the Mountain Iron Economic Development Authority, as presented. The motion carried unanimously.

It was moved by Skalko and seconded by Tuomela to authorize Mac's Bar, Inc., dba: Mac's Bar, to serve alcohol at the Sopp Wedding Reception on September 14, 2013, at the Mountain Iron Community Center. The motion carried unanimously.

The Council reviewed the list of communications. The City Administrator announced that the Greater Minnesota Agency informed the City that the 2014 Blue Cross/Blue Shield renewal would have a small increase of 1.5%.

At 7:46 p.m., it was moved by Zupancich and seconded by Tuomela to recess the regular meeting and enter into a closed meeting to discuss negotiation with management personnel, following a 10 minutes recess. The motion carried unanimously on a roll call vote.

Mayor Skalko called the closed meeting to order at 7:57 p.m. with the following members present: Joe Prebeg, Jr., Susan Tuomela, Tony Zupancich, Alan Stanaway, and Mayor Gary Skalko. Also present were: Craig J. Wainio, City Administrator.

The Council discussed the management contract negotiations for Sally Peterangelo.

At 8:34 p.m., it was moved by Zupancich and seconded by Tuomela that the closed meeting be adjourned and reconvene the regular meeting. The motion carried unanimously.

It was moved by Zupancich and seconded by Stanaway to approve the management contract for Sally Peterangelo, Library Director/Special Events Coordinator, as presented. The motion carried with Prebeg and Tuomela voting no.

At 8:38 p.m., it was moved by Skalko and seconded by Tuomela that the meeting be adjourned. The motion carried unanimously.

Submitted by:

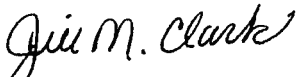

Jill M. Clark, MMC

Municipal Services Secretary

www.mtniron.com

COMMUNICATIONS

1. The Greater Minnesota Agency, forward the health insurance renewal information.
2. Tri-Cities Biosolids Disposal Authority, forwarding the 2014 budget information.
3. Biosolids Disposal Site Authority, forwarding the 2014 budget information.
4. Minnesota Department of Health, forward the sanitary survey report for the Mountain Iron Public Water System.

Summary By Category And Distribution

Category	Distribution	Amount
FINES	CRIMINAL	476.19
UTILITY	UTILITY	111,535.96
CAMPGROUND RECEIPTS	FEES	4,280.00
CAMPGROUND RECEIPTS	CREDIT CARD FEES	49.20
METER DEPOSITS	ELECTRIC	2,650.00
CHARGE FOR SERVICES	ELECTRIC-CHG FOR SERVICES	637.80
PERMITS	BUILDING	3,511.21
CD INTEREST	CD INTEREST 378	283.68
CD INTEREST	CD INTEREST601	23.48
CD INTEREST	CD INTEREST 602	189.77
CD INTEREST	CD INTEREST 603	175.98
CD INTEREST	CD INTEREST 604	309.72
BUILDING RENTALS	BUILDING RENTAL DEPOSITS	800.00
BUILDING RENTALS	LIBRARY	25.00
BUILDING RENTALS	COMMUNITY CENTER	900.00
MISCELLANEOUS	BLUE CROSS/BLUE SHIELD PAYABLE	33,713.23
MISCELLANEOUS	REIMBURSEMENTS	26,419.19
CD INTEREST	CD INTEREST 101	689.11
COPIES	COPIES	10.75
MISCELLANEOUS	MISC. - GENERAL	679.25
BUILDING RENTALS	SENIOR CENTER	50.00
MISCELLANEOUS	ASSESSMENT SEARCHES	50.00
INTERGOVERNMENTAL REVENUE	TACONITE PRODUCTION TAX	2,070,731.00
CHARGE FOR SERVICES	SEWER-CHARGE FOR SERVICES	1,173.68
SALE OF PROPERTY	SALE OF PROP-SO FOREST GR LOTS	-
SALE OF PROPERTY	SALE OF PROP-UNITY SECOND ADD	20,764.27
BUILDING RENTALS	NICHOLS HALL	125.00
MISCELLANEOUS	FIRE DEPT-MISC INCOME	3,020.00
MISCELLANEOUS	REFUSE-SALE OF SCRAP METAL	61.20
CHARGE FOR SERVICES	SERVICES, FEES, MISC.	.90
Summary Totals:		<u>2,283,335.57</u>

Check Issue Date(s): 09/03/2013 - 09/04/2013

Report Criteria:

Check.Check No = 144289-144356

Per	Date	Check No	Vendor No	Payee	Check GL Acct	Amount
09/13	09/04/2013	144289	10070	A-1 RENTAL SERVICES INC	101-20200	633.75
09/13	09/04/2013	144290	10074	AAA STRIPING SERVICE COMPANY	101-20200	9,844.00
09/13	09/04/2013	144291	10021	ARROWHEAD LIBRARY SYSTEM	101-20200	57.85
09/13	09/04/2013	144292	5007	ASSURANT EMPLOYEE BENEFITS	101-20200	802.58
09/13	09/04/2013	144293	20055	BARNES & NOBLE BOOKSELLERS	101-20200	293.37
09/13	09/04/2013	144294	20022	BENCHMARK ENGINEERING INC	301-20200	25,331.54
09/13	09/04/2013	144295	20010	BISS LOCK INC	101-20200	282.98
09/13	09/04/2013	144296	20014	BORDER STATES ELECTRIC SUPPLY	604-20200	1,172.43
09/13	09/04/2013	144297	30017	CARQUEST (MOUNTAIN IRON)	101-20200	299.69
09/13	09/04/2013	144298	170001	CENTURY LINK	101-20200	123.21
09/13	09/04/2013	144299	9093	CHRISTINE LUZOVICH	101-20200	100.00
09/13	09/04/2013	144300	220003	CITY OF VIRGINIA	101-20200	48.43
09/13	09/04/2013	144301	30026	COMO LUBE & SUPPLIES INC	101-20200	138.94
09/13	09/04/2013	144302	30072	COMPUTER WORLD	101-20200	1,111.00
09/13	09/04/2013	144303	9094	DAVID LOCKE	101-20200	60.00
09/13	09/04/2013	144304	40028	DITCH WITCH OF MINNESOTA INC	604-20200	69.25
09/13	09/04/2013	144305	40055	DOUCETTE'S SPECIAL EVENTS	101-20200	250.00
09/13	09/04/2013	144306	500012	ERA LABORATORIES INC	602-20200	317.10
09/13	09/04/2013	144307	9090	EVELETH CROSS COUNTRY TEAM	101-20200	100.00
09/13	09/04/2013	144308	60026	FASTENAL COMPANY	602-20200	154.51
09/13	09/04/2013	144309	60036	FILTRATION SYSTEMS INC	101-20200	630.37
09/13	09/04/2013	144310	60006	FISHER PRINTING COMPANY	604-20200	115.43
09/13	09/04/2013	144311	70004	GRANDE ACE HARDWARE	604-20200	181.69
09/13	09/04/2013	144312	70028	GREATER MINNESOTA AGENCY INC	101-20200	222.00
09/13	09/04/2013	144313	70029	GUARDIAN PEST CONTROL INC	101-20200	85.93
09/13	09/04/2013	144314	80044	HENKEL, BRENT	604-20200	32.05
09/13	09/04/2013	144315	80017	HENRY'S WATERWORKS INC	601-20200	1,311.20
09/13	09/04/2013	144316	80008	HIBBING EXCAVATION INC	301-20200	25,299.45
09/13	09/04/2013	144317	80001	HILLYARD/HUTCHINSON	101-20200	1,211.03
09/13	09/04/2013	144318	80037	HOMETOWN MEDIA PARTNERS	101-20200	555.76
09/13	09/04/2013	144319	9092	JOHN SKALKO	101-20200	200.00
09/13	09/04/2013	144320	190025	JUDY SEURER	101-20200	100.00
09/13	09/04/2013	144321	9095	KATHY BROPHY	101-20200	20.00
09/13	09/04/2013	144322	9091	KENDALL LIINDHOLM O'BRYAN	101-20200	200.00
09/13	09/04/2013	144323	120013	L & L RENTALS INC	101-20200	387.32
09/13	09/04/2013	144324	120032	LAKE COUNTRY POWER	101-20200	215.89
09/13	09/04/2013	144325	120002	LAWSON PRODUCTS INC	101-20200	304.94
09/13	09/04/2013	144326	120003	LEAGUE OF MINNESOTA CITIES	101-20200	40.00
09/13	09/04/2013	144327	130030	MACQUEEN EQUIPMENT	603-20200	481.01
09/13	09/04/2013	144328	8057	MELLIN PROMOTIONAL	101-20200	1,533.50
09/13	09/04/2013	144329	130026	MESABI SIGN COMPANY	101-20200	21.00
09/13	09/04/2013	144330	130135	MINNCOR INDUSTRIES	101-20200	914.85
09/13	09/04/2013	144331	130044	MINNESOTA DEPT OF HEALTH	601-20200	1,493.01
09/13	09/04/2013	144332	140026	MINNESOTA ENERGY RESOURCES	602-20200	11.98
09/13	09/04/2013	144333	130082	MINNESOTA MAYORS ASSOCIATION	101-20200	30.00
09/13	09/04/2013	144334	130009	MINNESOTA POWER (ALLETE INC)	101-20200	1,937.62
09/13	09/04/2013	144335	130117	MINNESOTA TRUCKING ASSOCIATION	101-20200	19.08
09/13	09/04/2013	144336	130047	MOBILE HEALTH SERVICES LLC	602-20200	450.00
09/13	09/04/2013	144337	130015	MOUNTAIN IRON PUBLIC UTILITIES	101-20200	18,334.92
09/13	09/04/2013	144338	140014	NELSON WILLIAMS LININGS INC	603-20200	1,111.50
09/13	09/04/2013	144339	140055	NORTHERN VISUAL SERVICES LLP	101-20200	30.00
09/13	09/04/2013	144340	40032	OFFICE OF ENTERPRISE TECHNOLOG	101-20200	415.24
09/13	09/04/2013	144341	160003	PERPICH TV & MUSIC INC	101-20200	53.43
09/13	09/04/2013	144342	160071	PURCHASE POWER	601-20200	1,000.00

Check Issue Date(s): 09/03/2013 - 09/04/2013

Per	Date	Check No	Vendor No	Payee	Check GL Acct	Amount
09/13	09/04/2013	144343	180004	RANGE COOPERATIVES	101-20200	54.50
09/13	09/04/2013	144344	190003	SARANEN AUTO	603-20200	30.43
09/13	09/04/2013	144345	190103	SHUBAT TRANSPORTATION COMPAN	101-20200	500.00
09/13	09/04/2013	144346	190102	SILVER CREEK LIQUOR CO.	101-20200	56.72
09/13	09/04/2013	144347	190004	SKUBIC BROS INC	101-20200	776.17
09/13	09/04/2013	144348	190002	ST LOUIS COUNTY AUDITOR	603-20200	18,103.25
09/13	09/04/2013	144349	200003	TACONITE TIRE SERVICE	602-20200	1,113.78
09/13	09/04/2013	144350	200006	TRIMARK INDUSTRIAL	101-20200	22.98
09/13	09/04/2013	144351	200009	TROPHY SHOP	101-20200	81.76
09/13	09/04/2013	144352	210010	ULLAND BROTHERS INC	301-20200	293,444.84
09/13	09/04/2013	144353	220025	VERIZON WIRELESS	602-20200	19.02
09/13	09/04/2013	144354	240001	XEROX CORPORATION	101-20200	30.37
09/13	09/04/2013	144355	260005	ZEP MANUFACTURING COMPANY	101-20200	284.85
09/13	09/04/2013	144356	260001	ZIEGLER INC	101-20200	3,567.15

Totals:

	<u>418,226.65</u>
Payroll-PP Ending 8/30/13	58,533.52
Electronic Trans.-Sales Tax 8/20/13	<u>15,122.71</u>
TOTAL EXPENDITURES	<u>\$491,882.88</u>



Agreement Between Energy Vendor and Service Provider

MOUNTAIN IRON CITY OF PUBLIC UTILITIES, 8586 ENTERPRISE DR S MT IRON MN 55768 and successor home energy providers, hereafter referred to as "the energy vendor", hereby agrees to cooperate with Arrowhead Economic Opportunity Agency -AEOA hereafter referred to as "the Service Provider", and the Minnesota Department of Commerce (MDOC), Energy Assistance Programs, hereafter referred to as "the State" to deliver the Minnesota Energy Assistance Program for Federal Fiscal Year 2014 (FFY 2014), October 1, 2013 through September 30, 2014.

I. The energy vendor and the Service Provider will:

1. Follow Energy Assistance Program (EAP) policies and procedures in the *EAP Policy Manual* (In particular Chapter 3).
2. Maintain accurate client and consumption information.
3. Comply with the Minnesota Government Data Practices Act (MGDPA), Minn. Stat. Ch. 13, as it applies to all data provided by the State under this agreement and as it applies to all data created, collected, received, stored, used, maintained or disseminated by the energy vendor or the Service Provider, in performing the duties under this agreement. In the administration of this program, the energy vendor and the service provider have access to a protected data base containing private information on individuals protected under the MGDPA. The energy vendor and the Service Provider agree to not release any private data, including from the database, to any third party without written authorization from the subject of the data.
4. Share information with each other as needed to perform the duties under this agreement.
5. Negotiate for continuation or reconnection of service to households determined eligible for EAP Primary Heat and EAP Crisis Benefits.
6. Establish a dispute resolution process to resolve issues arising during the term of this agreement.
7. Collaborate and do everything possible to ensure the customer has continuous access to home heating.
8. Minimize the risks of a customer's home energy crisis through the use of the Crisis Benefits.
9. Encourage regular payments from the household.
10. Collaborate to reduce home energy costs.
11. Work together to ensure EAP payments are appropriately applied to accounts and used for EAP services as designated by the Service Provider.

II. The Service Provider will:

1. Determine customer eligibility.
2. Provide new and existing energy vendors with information about the eHEAT software system.
 - Encourage all energy vendors to become an eHEAT user, allowing them access to eligibility and benefit data "online".
 - Provide necessary and/or ongoing training to energy vendors using eHEAT.
3. Make authorization through eHEAT, telephone, fax or electronic communication for:
 - Payments for electricity, heating fuels and delivery of fuel.
 - Continuation or reconnection of connected utilities.
 - Payments for fees including: service deposits, pressure tests, line bleeding, tank setting, tank rental, membership, if applicable.
 - Removal from load limiters.
 - Payments due and past due amounts for electricity and heating fuels.
4. Maintain a file of customer authorizations for exchange of private data between the Service Provider and the energy vendor.
5. Enter account number into eHEAT in the format supplied by the energy vendor.

III. The energy vendor will:

1. Ensure EAP eligible households are not treated adversely compared to other households. Oil and propane dealers are required to comply with the Discrimination Prohibition in Minn. Stat. §325E.027.
2. Supply account number format to the Service Provider.
3. Provide to the Service Provider a written price list for normal and customary services for home energy costs including but not limited to:
 - Leak seek and pressure tests
 - Bleeding lines
 - Tank setting
 - Service deposits
 - Reconnection fees
 - Membership fees
 - Minimum delivery requirements and costs
 - Emergency fuel and after hours delivery costs
4. When possible deliver remaining EAP benefit before September 30, 2014.
5. Provide at the request of the customer, the Service Provider or the State, information on applicant households' home energy costs, dwelling consumption data, delivery dates, bill payment history or arrearage history. This information will be provided in the format requested.
6. Provide dwelling consumption data within 5 business days of the request in eHEAT.
7. Respond promptly to consumption requests for crisis situations.
8. Register with EAP to receive payments.
9. Use the warrant or EFT date as the EAP payment date.
10. Apply all EAP payments to the households account within 5 business days of receipt of payment.
11. Apply EAP payments to the household's energy costs before applying other energy payments.

12. Accept all customer payments.
13. Use EAP funds to pay for home energy costs, including fuel and other routine and required services as designated by the Service Provider. Expenses such as service contracts, water, sewer, garbage, cable, internet, telephone, gasoline, machine parts, engine oil, etc. cannot be paid with EAP funds.
14. Continue service, reconnect or deliver fuel to households as negotiated by the Service Provider on behalf of the household.
15. When addressing household energy emergencies, when possible, accept eHEAT payment status of "Payable" for payment. When eHEAT is not available, accept early notification authorization by telephone, fax or electronic communication for delivery of fuel, continuation or reconnection of connected utilities, or service deposits if applicable, and removal from load limiters.
16. Accept a household application status in eHEAT of "approved" as income eligibility validation for the Energy Assistance Program.
17. Report dangerous heating or fuel delivery situations for EAP households to the Service Provider.
18. Process and refund to the State any refunds requested by the Service Provider within 10 business days.
19. Process and refund to the State all credits attributable to EAP payments made during FFY 2014 remaining on a customer's account within 10 business days after a client ceases to be a customer.
20. Upon customer request, return to the household any EAP funds remaining on the household's account after September 30, 2014.
21. Notify the Service Provider or DOC if there is reason to believe EAP funds have been misused as described in the EAP Policy Manual.
22. Allow the Service Provider or State access to fiscal records of EAP transactions for audit purposes for period of three (3) years after payment.
23. Complete and submit the *EAP Leveraging Report* to the State.
24. Use eHEAT when possible to administer EAP program business, including but not limited to:
 - Providing consumption
 - Maintaining energy vendor account numbers
 - Monitoring eligibility and payments
 - Recording refunds
25. Implement and maintain eHEAT database security policies by:
 - Limiting access to authorized personnel only
 - Ensuring each user is assigned a unique user ID
 - Ensuring email addresses associated with each user ID are current
 - Disabling users immediately upon termination of their role in the service delivery of EAP
 - Disabling users who are on a temporary leave of absence, extended vacation, etc

IV. Either party to this agreement may terminate it at any time, with or without cause, upon thirty days written notice to each other and the State. Upon termination, the energy vendor must provide an estimated final invoice for the energy vendor's services performed. Upon termination and submission of a final invoice, and upon acceptance of the final invoice by the state, the energy vendor will be entitled to payment for services satisfactorily performed.

V. Signatures:

Energy Vendor:		
Authorized Energy Vendor Representative:		
<u>GARY W SKALKO</u> Please Print Name	<u><i>Gary W Skalko</i></u> Signature	<u>9-4-13</u> Date
Company Contact Person:		
<u>CITY OF MOUNTAIN IRON</u> Please Print Name	<u>218 748-7570</u> Telephone	<u>218 748-7573</u> Fax
<u>()</u> 24 hour emergency number to address after hours emergencies	<u><i>csullivan@ci.mountain-iron.mn.us</i></u> E-mail address	
EAP Service Provider:		
Authorized Service Provider Representative:		
_____ Please Print Name	_____ Signature	_____ Date
Energy Assistance Coordinator:		
_____ Please Print Name	<u>()</u> Telephone	<u>()</u> Fax
<u>()</u> 24 hour emergency number	_____ E-mail address	



CITY OF MOUNTAIN IRON

"TACONITE CAPITAL OF THE WORLD"

PHONE: 218-748-7570 • FAX: 218-748-7573 • www.mtniron.com
8586 ENTERPRISE DRIVE SOUTH • MOUNTAIN IRON, MN • 55768-8260

RESOLUTION NUMBER 24-13

ACCEPTING WORK

WHEREAS, pursuant to a written contract signed with the City on August 24, 2011, Mesabi Bituminous of Gilbert, Minnesota has satisfactorily completed Improvement Number 11-05, the proposed improvement of Bluebell Avenue and Daffodil Avenue between the centerline of Unity Drive and the centerline of Jasmine Street by reconstruction or overlayment in accordance with such contract,

NOW THEREFORE, BE IT RESOLVED BY THE CITY COUNCIL OF THE CITY OF MOUNTAIN IRON, MINNESOTA, that the work completed under said contract is hereby accepted and approved, and,

BE IT FURTHER RESOLVED, that the City Administrator and Mayor are hereby directed to issue a proper order for the final payment on such contract, in exchange for the contractor's receipt evidencing payment in full.

DULY ADOPTED BY THE CITY COUNCIL THIS 3rd DAY OF SEPTEMBER, 2013.

ATTEST:

City Administrator



Mayor Gary Skalko



CITY OF MOUNTAIN IRON

"TACONITE CAPITAL OF THE WORLD"

PHONE: 218-748-7570 • FAX: 218-748-7573 • www.mtniron.com
8586 ENTERPRISE DRIVE SOUTH • MOUNTAIN IRON, MN • 55768-8260

RESOLUTION NUMBER 31-13

APPROVING PROPOSED 2013 TAX LEVY, COLLECTABLE 2014

BE IT RESOLVED, by the City Council of the City of Mountain Iron, County of Saint Louis, Minnesota, that the following sums of money be levied for the current year, collectable in 2014, upon the taxable property in the City of Mountain Iron for the following purposes:

TOTAL PROPOSED LEVY	\$1,206,978.00
---------------------	----------------

The City Administrator is hereby instructed to transmit a certified copy of this Resolution to the County Auditor of Saint Louis County, Minnesota.

DULY ADOPTED BY THE CITY COUNCIL THIS 3th DAY OF SEPTEMBER, 2013.

ATTEST:



City Administrator



Mayor Gary Skalko



CITY OF MOUNTAIN IRON

"TACONITE CAPITAL OF THE WORLD"

PHONE: 218-748-7570 • FAX: 218-748-7573 • www.mtniron.com
8586 ENTERPRISE DRIVE SOUTH • MOUNTAIN IRON, MN • 55768-8260

RESOLUTION NUMBER 32-13

APPROVING PROPOSED 2014 MARKET RATE BASED REFERENDUM LEVY FOR THE GENERAL OBLIGATION COMMUNITY CENTER BONDS AND INTEREST

WHEREAS, in February 1998 the voters in the City of Mountain Iron approved a market rate based referendum levy for bonds and interest to construct the Mountain Iron Community Center.

NOW, THEREFOR BE IT RESOLVED, by the City Council of the City of Mountain Iron, County of Saint Louis, Minnesota, that the following market rate based levy shall be made in 2013 payable in 2014 for all property in the City of Mountain Iron:

General Obligation Community Center Bond levy shall be \$83,811.00

The City Administrator is hereby instructed to transmit a certified copy of this resolution to the County Auditor of Saint Louis County, Minnesota.

DULY ADOPTED BY THE CITY COUNCIL THIS 3rd DAY OF SEPTEMBER, 2013.

ATTEST:

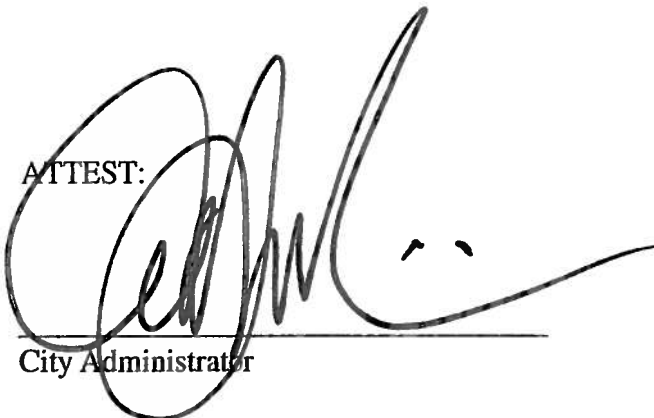

City Administrator

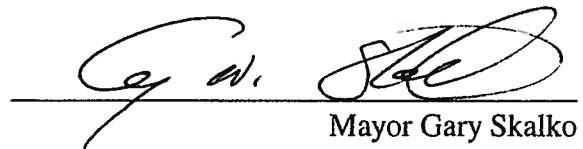

Mayor Gary Skalko



CITY OF MOUNTAIN IRON

"TACONITE CAPITAL OF THE WORLD"

PHONE: 218-748-7570 • FAX: 218-748-7573 • www.mtniron.com
8586 ENTERPRISE DRIVE SOUTH • MOUNTAIN IRON, MN • 55768-8260

RESOLUTION NUMBER 33-13

CONCERNING THE 2013 ECONOMIC DEVELOPMENT AUTHORITY TAX LEVY

WHEREAS, the Mountain Iron Economic Development Authority was created on the 19th day of April, 2004, pursuant to Minnesota Statutes 469.090-469.108 and;

WHEREAS, Minnesota Statutes, Section 469.107, Subdivision 1, specifically authorized the Mountain Iron Economic Development Authority to levy against the taxable property of the City of Mountain Iron, St. Louis County, Minnesota.

NOW, THEREFORE BE IT RESOLVED by the City Council of Mountain Iron, Minnesota, that for the purpose of further development and to provide for any activities that are within the jurisdiction of the Mountain Iron Economic Development Authority as defined according to Minnesota Statutes. The Mountain Iron City Council submits to the County Auditor of St. Louis County, Minnesota, a final tax levy with a levy set to the maximum allowable for the Mountain Iron Economic Development Authority.

DULY ADOPTED BY THE CITY COUNCIL THIS 3rd DAY OF SEPTEMBER, 2013.

ATTEST:

City Administrator

Mayor Gary Skalko



CITY OF MOUNTAIN IRON

"TACONITE CAPITAL OF THE WORLD"

PHONE: 218-748-7570 • FAX: 218-748-7573 • www.mtniron.com
8586 ENTERPRISE DRIVE SOUTH • MOUNTAIN IRON, MN • 55768-8260

RESOLUTION NUMBER 34-13

CALLING A HEARING ON PROPOSED ASSESSMENT

WHEREAS, by a resolution passed by the council on August 19, 2013, the City Administrator was directed to prepare a proposed assessment of the cost of Improvement Number M111-05 the improvements to the Mountain Iron Water System along County Road 7 between Spruce Drive and Southern Drive by installing a water main, and

WHEREAS, the City Administrator has notified the council that such proposed assessment has been completed and filed in his/her office for public inspection,

NOW THEREFORE, BE IT RESOLVED BY THE CITY COUNCIL OF MOUNTAIN IRON, MINNESOTA:

1. A hearing shall be held at 6:30 p.m. on October 7, 2013 in the Community Center located at 8586 Enterprise Drive South to pass upon such proposed assessment. All persons owning property affected by such improvement will be given an opportunity to be heard with reference to such assessment.
2. The City Administrator is hereby directed to cause a notice of the hearing on the proposed assessment to be published once in the official newspaper at least two weeks prior to the hearing, and he/she shall state in the notice the total cost of the improvement. He/She shall also cause mailed notice to be given to the owner of each parcel described in the assessment roll not less than two weeks prior to the hearing.
3. The owner of any property so assessed may, at any time prior to certification of the assessment to the county auditor, pay the whole of the assessment on such property, with interest accrued to the date of payment, to the City of Mountain Iron, except that no interest shall be charged if the entire assessment is paid within 30 days from the adoption of the assessment. An owner may at any time thereafter, pay to the City Administrator the entire amount of the assessment remaining unpaid, with interest accrued to December 31 of the year in which such payment is made. Such payment must be made before November 15 or interest will be charged through December 31 of the succeeding year.

DULY ADOPTED BY THE CITY COUNCIL THIS 3rd DAY OF SEPTEMBER, 2013.

ATTEST:

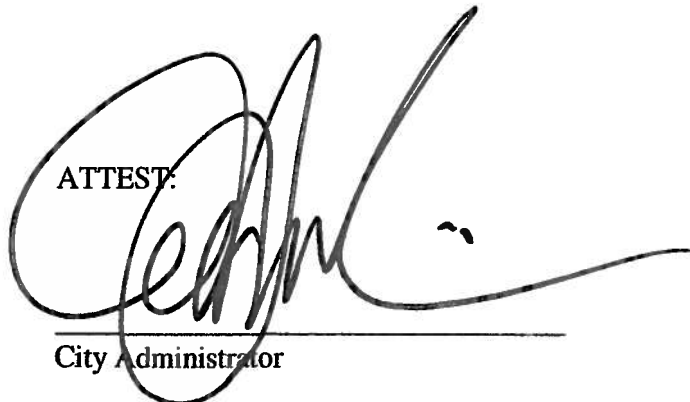

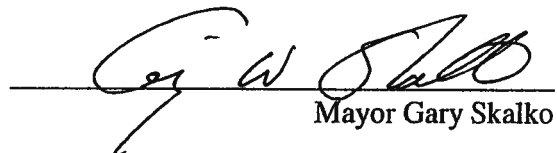
City Administrator

Mayor Gary Skalko

Parcel Code	Name	Address	City	Front Footage	Total	Assessment Amount	Per Foot
175-0071-01360	RGGS	100 WAUGH DRIVE SUITE 400	HOUSTON TX 77007	730	\$ 382,318.32	\$ 13,139.94	\$ 18.00
175-0071-01365	Mountain Iron EDA	8586 Enterprise Drive South	Mountain Iron MN 55768	286	\$ 51,479.77	\$ 5,147.98	\$ 18.00
175-0071-01395	Mountain Iron EDA	8586 Enterprise Drive South	Mountain Iron MN 55768	573	\$ 103,139.55	\$ 10,313.95	\$ 18.00
175-0071-01390	RGGS	100 WAUGH DRIVE SUITE 400	HOUSTON TX 77007	535	\$ 96,299.58	\$ 9,629.96	\$ 18.00
				2124	\$ 382,318.32	\$ 38,231.83	

COUNCIL LETTER 091613-IVB1

CAMPGROUND

FIXTURE QUOTE

DATE: September 12, 2013

FROM: Craig J. Wainio
City Administrator

Staff is seeking authorization to replace at fixtures in the bathrooms at the West Two Rivers Campground. Enclosed is a quote from Virginia Plumbing and Heating for the purchase and installation of the fixtures. This item would be funded through the capital improvement budget.

Arnesen's

Virginia Plumbing and Heating

114 South 15th Avenue West

Virginia, Minnesota 55792

Phone: (218)741-4313 Fax: (218)741-4313

E-Mail: vphco@mediacombb.net

9/10/13

TO: City of Mt. Iron

RE: West Two Rivers Campground fixture replacement

We are pleased to offer our estimate for the replacement of the faucets and flush valves at the campground. This estimate consists of removal of the existing items and replacement with new as per the submittal sheets:

1. 4- push button metered shower valves. Connect new shower valves to existing ½" copper supply line near ceiling at each shower.
2. 5- toilet flush valves.
3. 1- urinal flush valve.
4. 4- push button metered sink faucets.
5. New supply tubes for the new lavatory faucets.

Total estimate for the above: \$5,464.58

**If you have any questions or concerns regarding this estimate,
please feel free to contact us!**

Thank You!

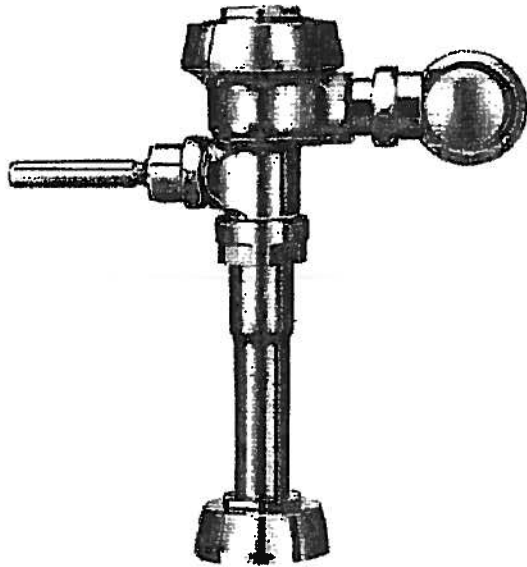

Royal® Model Flushometer

180

Description

Exposed Urinal Flushometer, for 1-1/4" top spud Urinals.

Flush Cycle

- Model 180-1.0 Low Consumption (1.0 gpf/3.8 Lpf)
- Model 180-1.5 Water Saver (1.5 gpf/5.7 Lpf)
- Model 180 Conventional (3.5 gpf/13.2 Lpf)

Specifications

Quiet, Exposed, Diaphragm Type, Chrome Plated Urinal Flushometer with the following features:

- PERMEX® Synthetic Rubber Diaphragm with Dual Filtered Fixed Bypass
- ADA Compliant Metal Oscillating Non-Hold-Open Handle with Triple Seal Handle Packing
- 1" I.P.S. Screwdriver Bak-Chek® Angle Stop with Free Spinning Vandal Resistant Stop Cap
- Adjustable Tailpiece
- High Back Pressure vacuum breaker flush connection w/ one-piece bottom hex coupling nut
- Spud Coupling and Flange for 1 1/4" Top Spud
- Sweat Solder Adapter w/Cover Tube & Cast Wall Flange w/Set Screw
- High Copper, Low Zinc Brass Castings for Dezincification Resistance
- Non-Hold-Open Handle, Fixed Metering Bypass and No External Volume Adjustment to Ensure Water Conservation
- Flush Accuracy Controlled by CID Technology
- Diaphragm, Handle Packing, Stop Seat and Vacuum Breaker molded from PERMEX Rubber Compound for Chloramine Resistance
- 100% of the energy used in manufacturing is offset with Renewable Energy Sources -- Wind Energy

Valve Body, Cover, Tailpiece and Control Stop shall be in conformance with ASTM Alloy Classification for Semi-Red Brass. Valve shall be in compliance to the applicable sections of ASSE 1037 and ANSI/ASME A112.19.2.

Variations

- HL-3 3" Metal Oscillating Push Button on front of valve (does not meet ADA requirements)
- T 1-1/2" Flush Connection
- SG SaniGuard® Antimicrobial Protects Handle and Socket*

* SaniGuard does not protect users or others against disease-causing bacteria.

Accessories

See Accessories Section of the Sloan catalog for details on these and other Flushometer variations.

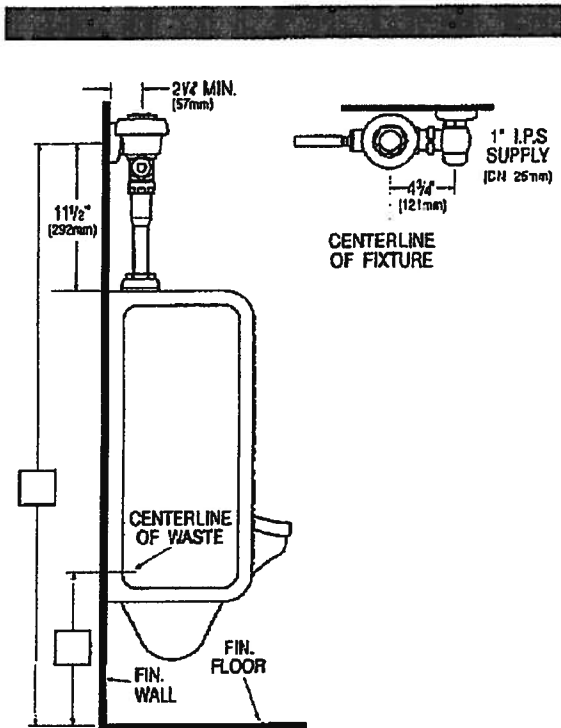

This space for Architect/Engineer approval

Job Name _____ Date _____

Model Specified _____ Quantity _____

Variations Specified _____

Customer/Wholesaler _____

Contractor _____

Architect _____

The information contained in this document is subject to change without notice.



SLOAN HEADQUARTERS • 10500 SEYMOUR AVENUE • FRANKLIN PARK, IL 60131
 Pfx 1-800-982-5839 • Fax: 1-800-447-8329 • www.sloanvalve.com

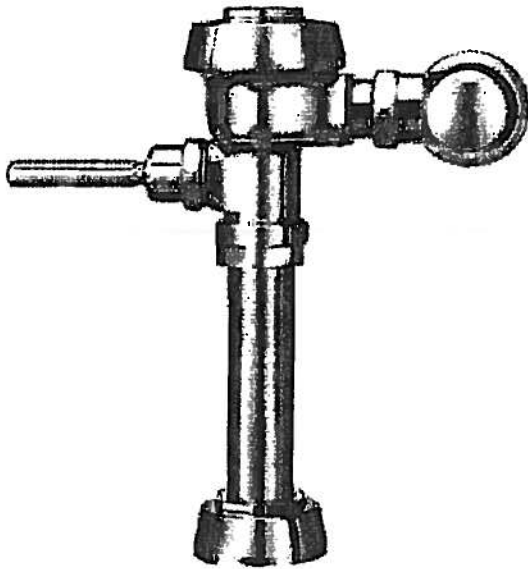

Royal® Model Flushometer

110/111

Description

Exposed Water Closet Flushometer, for floor mounted or wall hung top spud bowls.

Flush Cycle

- Model 110 Water Saver (3.5 gpf/13.2 Lpf)
- Model 111 Low Consumption (1.6 gpf/6.0 Lpf)

Specifications

Quiet, Exposed, Diaphragm Type, Chrome Plated Closet Flushometer for left or right hand supply with the following features:

- PERMEX® Synthetic Rubber Diaphragm with Dual Filtered Fixed Bypass
- ADA Compliant Metal Oscillating Non-Hold-Open Handle with Triple Seal Handle Packing
- 1" I.P.S. Screwdriver Bak-Chek™ angle stop w/ free spinning vandal resistant stop cap
- Adjustable Tailpiece
- High Back Pressure Vacuum Breaker Flush Connection w/ One-piece Bottom Hex Coupling Nut
- Spud Coupling and Flange for 1-1/2" Top Spud
- Sweat Solder Adapter w/Cover Tube & Cast Wall Flange w/Set Screw
- High Copper, Low Zinc Brass Castings for Dezincification Resistance
- Non-Hold-Open Handle, Fixed Metering Bypass and No External Volume Adjustment to Ensure Water Conservation
- Flush Accuracy Controlled by CID Technology
- Diaphragm, Handle Packing, Stop Seat and Vacuum Breaker molded from PERMEX Rubber Compound for Chloramine Resistance

Valve Body, Cover, Tailpiece and Control Stop shall be in conformance with ASTM Alloy Classification for Semi-Red Brass. Valve shall be in compliance to the applicable sections of ASSE 1037.

Variations

- XYV Valve Less Vacuum Breaker
- SG SaniGuard® Antimicrobial Coating Protects Handle and Socket*

* SaniGuard does not protect users or others against disease-causing bacteria.

Accessories

See Accessories Section of the Sloan catalog for details on these and other Flushometer variations.

Fixtures

Consult Sloan for Sloan brand matching fixture options.

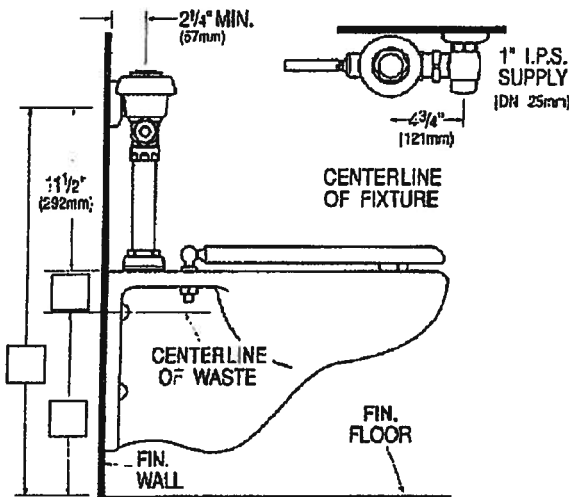

Made in The
USA



GREEN
POWER
PARTNER



This space for Architect/Engineer approval	
Job Name _____	Date _____
Model Specified _____	Quantity _____
Variations Specified _____	
Customer/Wholesale _____	
Contractor _____	
Architect _____	

The information contained in this document is subject to change without notice.

SLOAN

SLOAN HEADQUARTERS • 10500 SEYMOUR AVENUE • FRANKLIN PARK, IL 60131

Ph: 1-800-932-5839 • Fax: 1-900-447-8329 • www.sloanvalve.com

3-330

Showeroff® exposed shower limiter valve with integral stop, wall flange, union and street ell with escutcheon. 20" head riser with extended head bracket. Fre-Flo shower head with adjustable spray. Nozzle-type design for maximum protection against hard water mineral build-up.

Suffix A: Anchor plate for use with ceramic tile

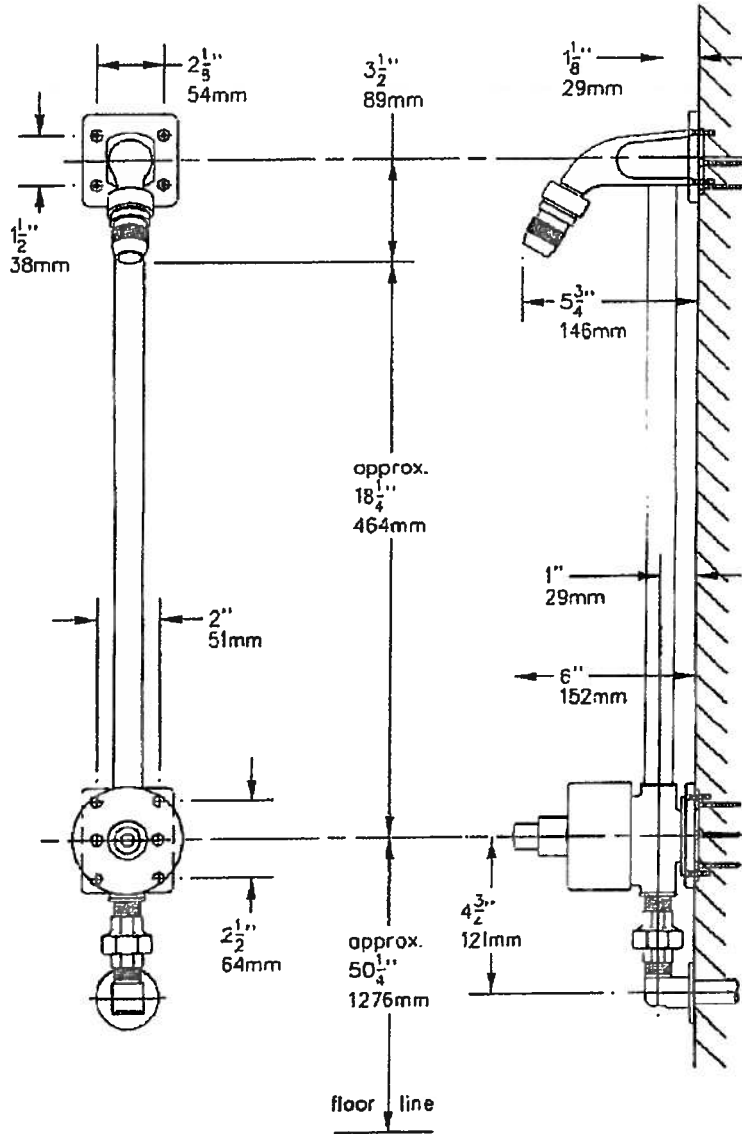

This drawing to be used for rough-in installation only. All floor to center dimensions optional. Concealed piping and fittings not furnished by manufacturer. For ADA compliance (Americans with Disabilities Act) consult ADAAG or your state regulations for proper product choice and mounting locations. For complete installation, adjustment and service information see installation instructions.

Symmons Industries, Inc. ■ 31 Brooks Drive ■ Braintree, MA 02164
 (800) 796-6667, (781) 848-2250 ■ Fax (800) 961-9621, (781) 843-3849
 Website: www.symmons.com ■ Email: customerservice@symmons.com

©2003, 2008 Symmons Industries, Inc. Printed in U.S.A. ■ 050608



COUNCIL LETTER 091613-IVB2

ADMINISTRATION

LIBRARY SUB

DATE: September 12, 2013

FROM: Craig J. Wainio
City Administrator

Enclosed, please find a letter of resignation from the current library substitute. It is recommended that the City Council accept the letter of resignation and authorize staff to post and advertise for this position.

September 5, 2013

Dear Sally,

This is my two-week notice to resign as Library Substitute. My last date available will be Saturday, September 21, 2013.

I have thoroughly enjoyed my work at the Mountain Iron Library under your expert direction and with your extremely well-read "book whisperer" Rhonda. Your and Rhonda's focus on customer service has enhanced my own service skills and, more importantly, added to the sense of community for my hometown and its beautiful library.

Thank you for having me as part of your team.

Sincerely,

A handwritten signature in black ink that reads "Tracy Kenyon". The signature is written in a cursive style with a large, stylized 'K' and 'Y'.

Tracy Kenyon



WESCO
DISTRIBUTION®

5151 INDUSTRIAL BLVD
INC
FRIDLEY MN 55421

Quotation

UNLESS THERE ARE DIFFERENT OR ADDITIONAL TERMS AND CONDITIONS CONTAINED IN A MASTER AGREEMENT THAT MODIFY WESCO'S STANDARD TERMS, BUYER AGREES THAT THIS QUOTE AND ANY RESULTING PURCHASE ORDER WILL BE GOVERNED BY WESCO'S TERMS AND CONDITIONS DATED 011107 AVAILABLE AT [HTTP://WWW.WESCO.COM/TERMS_AND_CONDITIONS_OF_SALE.PDF](http://www.wesco.com/terms_and_conditions_of_sale.pdf), WHICH TERMS ARE INCORPORATED HEREIN BY REFERENCE AND MADE PART HEREOF. PLEASE CONTACT THE SELLER IDENTIFIED ON THIS QUOTE IF YOU REQUIRE A PRINTED COPY.

To: CITY OF MOUNTAIN IRON
8866 SLATE STREET

MOUNTAIN IROMN 55768

Date: 09/06/13
Branch: 7859
Project Number: QUOTE
Project Name
Quoted To:
Date of Your Inquiry: 09/06/13
When ordering please refer to Quotation Number: 581738

Item	Quantity	Catalog Number and Description	Unit Price	U/M	Total Price	Rate of Cash Discount	Shipping Time (Weeks)
1	1000	WIRE 600V UD 4/0 SWTBRIAR FLEX 10 SERIES 8000 FLEXIBLE WIRE 1000' REELS +, - 10% LENGTH TOLERANCE STOCK	1620.000	M	1620.00	0.00	
2	2750	WIRE 15KV EPR 1/0 SOL 220 16 2750 SOUTHWIRE 1/0 SOLID ALUM, 15KV, 220MIL, EPR, 16 X #14 JACKETED CABLE 2750' REEL +, - 10% LENGTH TOLERANCE STOCK. SUBJECT TO PRIOR SALE NET 30 DAYS FREIGHT ALLOWED	2540.000	M	6985.00	0.00	

F.O.B. Point of Shipment. The prices stated in this offer shall, unless renewed, automatically expire fifteen days (15) from the date of this offer.

Per:

**BORDER STATES**

Supply Chain Solutions™

Border States Electric Supply
Harris Electric Supply - UtiliCorBorder States Electric - DUL
BSE - Duluth
4451 Airpark Blvd
Duluth MN 55811-5728
Phone: 218-727-8170Mountain Iron Lgt & Water Dept
8586 Enterprise Dr South
Mountain Iron MN 55768-8260**Quote**

Page: 1 of 1

BSE Quote: 23072401
Sold-to Acct #: 5047
Valid From: 09/10/2013 To: 09/17/2013
PO No: Cable Quote
PO Date: 09/10/2013Created By: Christopher Akers
Tel No: 701-239-2386
Fax No: 701-232-7673Inco Terms:
FOB ORIGINPayment Terms:
Net 25th prox

Taxes, if applicable, are not included.

Cust Item	BSE Item	Material MFG - Description	Quantity	Price	Per UoM	Value
	000010	2613349 BICC - 1/0 SOLID 220 EPR 16#14 JKT 2750FT 1/0 Solid Aluminum, .220 EPR 15KV, 133% 16#14 plain copper neutrals .050 LLDPE Jacket with 3- extruded red stripes with sequential foot mark Industry spec: AEIC CS8 and ICEA S-94-649 On non returnable wood reels 2750ft Delivery: 0 Days	2,750 FT	2.56 / 1	FT	7,040.00
	000020	166054 ALUT - 4/0-2/0-4/0 UDS8000 SWEETBRIR YN AL 1000 Delivery: 0 Days	1,000 FT	1.69 / 1	FT	1,690.00
Total Value						8,730.00

To access BSE's Terms and Conditions of Sale, please go to
<https://www.borderstateselectric.com>

<p>This quote has not been reviewed for compliance with the Buy American Act or the American Recovery and Reinvestment Act requirements. BSE reserves the right to amend both our bill of material and our proposal accordingly if BAA/ARRA compliance is required.</p>

QUOTE # 13BSG133
 QUOTED DATE 8/30/13

MOUNTAIN IRON PUBLIC UTILITY
 MOUNTAIN IRON, MN 55768
 ATTN: MIKE

<u>DESCRIPTION</u>	<u>PRODUCT NUMBER</u>	<u>QTY</u>	<u>UNIT PRICE</u>
TRANSFORMER LOSS DATA IS BASED ON ANSI C57.12.00: LOSS GRT: AVE TEMP BASIS: X VOLT% : 100 FOB MOUNTAIN IRON, MN. FREIGHT PREPAID & ALLOWED. *UNITS ARE QUOTED PER REQUEST FOR QUOTE ONLY. PRICES ARE FIRM FOR RECEIPT OF AN ORDER WITHIN 30 DAYS FROM 8/30/13 AND DELIVERY WITHIN THE QUOTED LEAD TIME. DELIVERIES BEYOND THE QUOTED LEAD TIME WILL BE SUBJECT TO ESCALATION BASED ON THE ERMCO MATERIAL PRICE INDEX AT THE TIME OF SHIPMENT. THE BASE ERMCO MATERIAL PRICE INDEX FOR THIS QUOTATION IS -15.64% LEADTIMES SUBJECT TO CHANGE WITHOUT NOTICE LEADTIME IS 8 - 10 WKS.			

ITEM 1			
ERMCO 3 PHASE PAD TRANSFORMER		1	5,085.00

NL= 211 LL= 1507

ERMCO
 0112 112.5 KVA
 G GRDY
 062 13800GY/7970 95 BIL
 X HO/XO GROUND
 001 NO TAPS
 112 208Y/120
 S5 ANSI SPECIFIC K DIM=5.0
 L LOOP FEED
 000 ERMCO STD FIXED STUD WELL
 G15 STD INSERT SYSTEM SELECT
 000 ELBOW ARRESTERS NOT SELECTED
 S STAGGERED LV BUSHING ARRANGEMENT
 000 ERMCO STD STUD LV BUSHINGS
 400 4 HOLE NEMA SPADES
 E58 DUAL SENSING BAYO & LINK (GENERIC)
 A00 STD ISOLATION LINK BY CONFIGURATOR
 000 MILD STEEL TANK & PEDESTAL
 000 MILD STEEL CABNET & SILL
 0 STD CABINET PARTITION
 0 PADMOUNT GREEN FINISH
 0 STANDARD HARDWARE.

QUOTE # 13BSG133
 QUOTED DATE 8/30/13

MOUNTAIN IRON PUBLIC UTILITY
 MOUNTAIN IRON, MN 55768
 ATTN: MIKE

<u>DESCRIPTION</u>	<u>PRODUCT NUMBER</u>	<u>QTY</u>	<u>UNIT PRICE</u>
11	SILICON BRONZE PENTABOLT		
0	GROUND BOSS IN PRIMARY & SECONDARY		
00	STANDARD AIR SPACE		
00	GENERIC PR VALVE .25 10PSI 35SCFM		
Z	ERMCO STD DRAIN VALVE W/ SAMPLER		
0	1"NPT FILL PLUG		
Z	SEC ERMCO STD LEVEL GAGE		
0	NO VACUUM GAGE SELECTED		
Z	ERMCO STD TEMPERATURE GAGE		
0	STD TX OIL		
A	STANDARD TWO NAMEPLATES		
00	STD KVA DECAL OUTSIDE		
00	DOES NOT REQUIRE PCB DECAL.		
11	"DANGER" MR OUCH GENERIC		
02	WARNING "MR OUCH" GENERIC		
99	STD PRIMARY DECAL INSIDE (HV)		
00	NO SECONDARY VOLTAGE DECALS		
00	STD ERMCO "E" LOGO DECAL		
N	NO SPECIAL TEST NEEDED		

100% CTR MONTHLY BY EMAIL 24

HOUR NOTICE

DELIVERY TO BE FLAT BED

SINCERELY,

BRAD GRABE

CUSTOMER SERVICE REPRESENTATIVE

Border States Electric - DUL
 BSE - Duluth
 4451 Airpark Blvd
 Duluth MN 55811-5728
 Phone: 218-727-8170

Quote

Page: 2 of 2

BSE Quote: 23062658
 Sold-to Acct #: 5047
 Valid From: 08/28/2013 To: 09/27/2013

Only routine tests as defined per IEEE C57.12.00-2010, Table 18 shall be performed on all transformers. Additional design tests can be provided at additional cost. Short circuit testing shall not be performed.

All 3 phase padmount transformers will be designed and manufactured in accordance with the latest revision of IEEE Standards C57.12.34 and C57.12.28.

Notice: For three phase pad-mounted transformers for both mineral oil and FR3 units, for those line items 500kVA and below, Cooper Power Systems will provide a discount for orders in quantities of 3 or more units that are a single design for one delivery date to the same location.

The amount of the discount will be:

- > 2.6% for 3 or 4 units
- > 3.4% for 5 or more units (or FTL for larger units)
- > 4.3% for 10 units or more

This discount is taken off of the single unit pricing provided in this proposal.

Cust Item	BSE Item	Material MFG - Description	Quantity	Price	Per UoM	Value
	000010	- 112.5KVA 3PH 13.8GY-208Y/120 DOE Product Lead-time (X): 16-17 weeks ex-factory	1 EA	5,370.00 / 1	EA	5,370.00
DESCRIPTION: kVA: 112.5 kVA 3 Phase Pad-Mounted Transformer Temperature Rise: 65 degree average winding rise Cooling Class: ONAN Insulating Fluid: Mineral Oil Efficiency Standard: DOE 2010, 10 CFR Part 431 Primary Voltage: 13800GY/7970 Volts, 95 kV BIL kV Class: 15 kV Primary Configuration: Dead Front, Loop Feed Taps No Taps Primary Bushings: 200 amp Cooper bushing wells (Quantity: Six (6)) Expulsion Fuses: Bayonet fuses (Quantity: Three (3)) Bayonet Holder: Copper Bayonet Fuse Holder (Quantity: Three (3)) Secondary Voltage: 208Y/120 Volts, 30 kV BIL Secondary kV Class: 1.2 kV Secondary Bushings: 5/8" copper stud with 4-hole screw-on spade bushing(s) (Quantity: Four (4)) Cabinet Hardware: Penta-head cabinet door bolts IEEE K-Dimension: Loop feed per IEEE C57.12.34-2009 Figure 11 minimum dimensions (without bails) Coatings: Munsell Green (Munsell 7GY 3.29/1.5) topcoat Gauges & Fittings: Drain plug in LV Compartment Gauges & Fittings: Pressure relief device, 35 SCFM Tank Accessories: IEEE standard one-hole ground pads (Quantity: Three (3)) Packaging: Pallet Cover: Bolted cover PERFORMANCE DATA: ** Losses are For Reference Only** No Load Losses @20 C: 208 Watts Load Losses @85 C: 1537 Watts Delivery: 17 Weeks						

Total Value

5,370.00

To access BSE's Terms and Conditions of Sale, please go to
<https://www.borderstateselectric.com>

This quote has not been reviewed for compliance with the Buy American Act or the American Recovery and Reinvestment Act requirements. BSE reserves the right to amend both our bill of material and our proposal accordingly if BAA/ARRA compliance is required.



WESCO
DISTRIBUTION

5151 Industrial BLVD NE
Fridley, MN 55421-1010
763-528-9713
800-328-9557 ext 713
FAX 763-528-9701
cmacynski@wesco.com

UNLESS THERE ARE DIFFERENT OR ADDITIONAL TERMS AND CONDITIONS CONTAINED IN A MASTER AGREEMENT THAT MODIFY WESCO'S STANDARD TERMS, BUYER AGREES THAT THIS QUOTE AND ANY RESULTING PURCHASE ORDER WILL BE GOVERNED BY WESCO'S TERMS AND CONDITIONS DATED 011107 AVAILABLE AT [HTTP://WWW.WESCO.COM/TERMS_AND_CONDITIONS_OF_SALE.PDF](http://www.wesco.com/terms_and_conditions_of_sale.pdf), WHICH TERMS ARE INCORPORATED HEREIN BY REFERENCE AND MADE PART HEREOF. PLEASE CONTACT THE SELLER IDENTIFIED ON THIS QUOTE IF YOU REQUIRE A PRINTED COPY

To: Mountain Iron PUC

Date: 8-30-13

Attn: Mike Downs

WESCO is pleased to quote you on the following ABB transformer.

ABB

ITEM	QTY	kVA	EACH (USD)	NL	LL	TL	%Z	Shipment
10	1	112.5	\$5,829	257 @ 85	1284 @ 85	1541	3.69	7-9 Weeks

Quoted loss values are guaranteed average values.

Lead times for orders subject to drawing approval will be confirmed upon receipt of approval and release for manufacturing.

Description:

Type : Liquid-Filled MTR Padmounted Transformer
Fluid : Mineral Oil
Core : Grain Oriented Steel
Phase : 3 Phase
Frequency : 60 Hz
Average Winding Rise : 65 °C
Ambient Temperature : 30 °C
High Voltage : 13800GrdY/7970
High Voltage Taps : +2 -2 2.5%
High Voltage BIL : 95kV BIL
Low Voltage : 208Y/120

Low Voltage BIL : 30kV BIL
Neutral : H0X0 bushing with ground strap
Feed Configuration : Loop feed
Color : Green (Munsell 7GY 3.29/1.5)
Customer Specification : Per RFQ.

Features (included in price):

TANK & CABINET

- Penta-head cabinet handle bolt

BUSHINGS

- Threaded stud LV bushings x 4
- Loadbreak Inserts (dead front) x 6
- HV Bushing pattern per ANSI standard C57.12.26, Fig 6A & 7 (5.0" spacing)
- 200 amp HV bushing wells x 6
- 4-hole NEMA spade terminals x 4
- ANSI C57.12.26 Fig 7&8a specific stgrd LV bushing pattern

FUSES

- Fused bayonet with isolation link x 3

MONITORING

- Pressure relief valve

FITTINGS

- Drain valve and sampler

MARKINGS

- NEMA Mr OUCH warning/danger decals shipped in a bag

OTHER

- 9.5" x 17.5" Tank Handhole Cover
- 18" deep cabinet
- DOE Efficiency (2010)
- RUS specification
- L_ASf33425a3-c01c-49a2-980f-a815a974d5a6

Terms and Conditions:

- Quote validity period: 30 days
- Payment Terms: Payment is due Net 45 Days from invoice date.
- Freight Terms: Shipment is FOB - Free on board - Origin
- Warranty: 18 months from delivery or 12 months from commissioning, whichever occurs first.

Shipments:

- Lead times are subject to change based on availability of production space and/or materials at time of order. Please contact your ABB representative to confirm the lead time at order entry.
- Lead times for orders requiring drawing approval will be confirmed after receipt of approval and release for manufacturing.
- Transportation costs are based on truckload quantities and one stop within the 48 contiguous states of the United States. Multiple stops will be charged a minimum of \$150 per stop.
- Packaging and handling beyond what is stated in the quote, including blue water transport, are at the expense of the purchaser.
- Shipments by dedicated truck must be specified as such on the purchase order and billed accordingly.
- This quote does not include installation, training and field testing unless noted otherwise.
- For destinations outside of the United States, purchaser is to identify seller for customs

MINUTES
SAFETY COMMITTEE MEETING
SEPTEMBER 3, 2013

The meeting was called to order at 1:33 p.m. with the following members present Judy Seurer, Accounting Technician; Sally Peterangelo, Library Director; Len Albrecht, Laborer; Jill Clark, Municipal Services Secretary and Michael Downs, Director of Public Works.

It was moved by Clark and supported by Peterangelo to approve the minutes of the July 1, 2013. The motion carried.

There were no lost-time accidents to report for July or August. There were two eye incidents involving an allergic reaction with the summer laborers. It was determined there was no way to prevent the incidents.

The monthly safety incentive raffle prize for July was awarded to Dennis Riccio. The monthly safety incentive raffle prize for August was awarded to Tim Satrang.

The results of the mock OSHA inspection were discussed. All issues found have been resolved.

The Committee discussed the MMUA Safety Management Program Contract proposed for 2013-2014.

It was moved by Downs and supported by Clark to recommend approval of the 2013-2014 Safety Management Program Contract (a copy of which is attached and made a part of these minutes) to the City Council. The motion carried.

It was moved by Downs and supported by Seurer to table discussion of the snowplowing policy and fleet safety policy to the next Committee meeting. The motion carried.

At 1:48 p.m., it was moved by Clark and supported by Peterangelo to adjourn the meeting. The motion carried and the meeting was adjourned.



Minnesota Municipal Utilities Association

August 26, 2013

MEMORANDUM

To: Safety Management Participants

From: Mike Willetts, Director of Job Training and Safety

Subject: 2013-14 Safety Management Program Contract

It is time to renew your safety management program contract. Since our group meeting, all requested changes have been made. There has been very little change from the budgets delivered at the earlier meeting. The contract amendments will cover October 1, 2013 through September 30, 2014, to coincide with MMUA's fiscal year.

Two copies of your contract amendment are enclosed. Please sign both contracts keeping one for your records and mailing the other to the address shown below. Please do not send payment at this time. You will be billed October 1. Mail your signed contract to:

Larry Pederson, Director of Finance
Minnesota Municipal Utilities Association
3025 Harbor Lane North, Suite 400
Plymouth, MN 55447-5142

If you have any concerns with the new contract, please contact me or Larry as follows:

Mike Willetts: phone 763-746-0705 or e-mail mwilletts@mmua.org
Larry Pederson: phone 763-746-0704 or e-mail lpederson@mmua.org

Thank you for being part of MMUA's safety management groups. With this program and your support we have proven that working together as a group we can develop a safety program that is affordable and at the same time works.

Minnesota Municipal Utilities Association
AMENDMENT TO SERVICES AGREEMENT
Safety Management Program

Contract Date: August 12, 2013

Contract Number: 20-2014

The services agreement entered into between Minnesota Municipal Utilities Association (MMUA) and Mountain Iron Public Utilities (Mountain Iron), dated August 27, 2012, contract number 20-2013, is amended as follows:

PART II, Section 1.

1. DURATION: This Agreement shall remain in force from October 1, 2013 until September 30, 2014 (the "expiration date").

PART III, Section 1.

1. COMPENSATION: For the services covered by this Agreement, Mountain Iron shall pay MMUA an annual fee of nine thousand six hundred dollars and 00 cents (\$ 9,600.00) for the 2013-14 annual period. Such compensation shall be due and payable according to the selected payment terms below.

Payment terms for the fee agreed to above shall be based on one of the following options (select one):

- Annual Payment (\$ 9,600.00)
- Quarterly Payments (\$ 2,400.00 each)

For any term of less than twelve full calendar months, the fee shall be a portion of the annual fee, pro-rated based on the number of calendar months or partial calendar months in which the services were provided as a percentage of twelve (12).

The parties hereby accept the terms of the Agreement as modified.

Mountain Iron Public Utilities
By _____
Title _____
Date _____
Purchase Order # _____

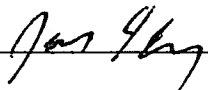
Minnesota Municipal Utilities Association
By 
Title Executive Director
Date August 12, 2013

Minnesota Municipal Utilities Association
AMENDMENT TO SERVICES AGREEMENT
Safety Management Program

Contract Date: August 12, 2013

Contract Number: 20-2014

The services agreement entered into between Minnesota Municipal Utilities Association (MMUA) and Mountain Iron Public Utilities (Mountain Iron), dated August 27, 2012, contract number 20-2013, is amended as follows:

PART II, Section 1.

1. DURATION: This Agreement shall remain in force from October 1, 2013 until September 30, 2014 (the "expiration date").

PART III, Section 1.

1. COMPENSATION: For the services covered by this Agreement, Mountain Iron shall pay MMUA an annual fee of nine thousand six hundred dollars and 00 cents (\$ 9,600.00) for the 2013-14 annual period. Such compensation shall be due and payable according to the selected payment terms below.

Payment terms for the fee agreed to above shall be based on one of the following options (select one):

- Annual Payment (\$ 9,600.00)
- Quarterly Payments (\$ 2,400.00 each)

For any term of less than twelve full calendar months, the fee shall be a portion of the annual fee, pro-rated based on the number of calendar months or partial calendar months in which the services were provided as a percentage of twelve (12).

The parties hereby accept the terms of the Agreement as modified.

Mountain Iron Public Utilities
By _____
Title _____
Date _____
Purchase Order # _____

Minnesota Municipal Utilities Association
By  _____
Title Executive Director
Date August 12, 2013

Minnesota Municipal Utilities Association
Safety Management Program
Northeast Group Fee Calculation (Dave Lundberg)
 October 1, 2013 - September 30, 2014

City	Population	2013-14 Annual Charge	2013-14 Quarterly Charge	2012-13 Annual Charge	Difference	Total 2013-14 with JTS	# of Days
Aitkin	2,127	\$13,600.00	\$3,400.00	\$13,300.00	\$300.00	\$13,600.00	2
Gilbert	1,799	\$4,775.00	\$1,193.75	\$4,475.00	\$300.00	\$4,775.00	0.5
Grand Marais	1,419	\$13,600.00	\$3,400.00	\$13,300.00	\$300.00	\$15,250.00	2
Keewatin	1,172	\$8,100.00	\$2,025.00	\$7,800.00	\$300.00	\$9,200.00	1
Moose Lake	2,445	\$13,600.00	\$3,400.00	\$13,300.00	\$300.00	\$16,350.00	2
Mora	3,568	\$6,200.00	\$1,550.00	\$5,900.00	\$300.00	\$6,200.00	0.58
Mountain Iron	2,843	\$9,600.00	\$2,400.00	\$9,300.00	\$300.00	\$11,250.00	1
Nashwauk	949	\$8,100.00	\$2,025.00	\$7,800.00	\$300.00	\$8,100.00	1
Princeton	4,503	\$8,901.65	\$2,225.41	\$8,601.65	\$300.00	\$11,651.65	1
Princeton (city)	4,503	\$8,601.65	\$2,150.41	\$8,301.65	\$300.00	\$8,601.65	1
Lakes RSG		\$14,400.00	\$3,600.00	\$14,400.00	\$0.00	\$14,400.00	1
Pine RSG		\$7,200.00	\$1,800.00	\$7,200.00	\$0.00	\$7,200.00	0.5
Vermillion RSG		\$7,200.00	\$1,800.00	\$12,000.00	(\$4,800.00)	\$7,200.00	0.5
Lake Superior RSG		\$7,200.00	\$1,800.00	\$7,200.00	\$0.00	\$7,200.00	0.5
Circle Pines RSG		\$14,400.00	\$3,600.00	\$0.00	\$14,400.00	\$14,400.00	0.5
Region 3 RSG		\$0.00	\$0.00	\$7,200.00	(\$7,200.00)	\$0.00	0.5
Totals:		\$145,478.30	\$36,369.58	\$140,078.30	\$3,000.00	\$155,378.30	15.58

Contract runs 6/1/2013 - 5/31/2014
 (7 per year)
 Moved to Central group for 2013-14

Annual JTS (Electric)	per lineman	2013-14	2012-13
Aitkin	0	\$0.00	\$0.00
Gilbert	0	\$0.00	\$0.00
Grand Marais	3	\$1,650.00	\$1,650.00
Keewatin	2	\$1,100.00	\$1,100.00
Moose Lake	5	\$2,750.00	\$2,750.00
Mora	0	\$0.00	\$1,100.00
Mountain Iron	3	\$1,650.00	\$1,650.00
Nashwauk	0	\$0.00	\$0.00
Princeton	5	\$2,750.00	\$2,750.00
Totals:	18	\$9,900.00	\$11,000.00

Please notify Larry Pederson of changes to your city.



www.royaltire.com

Promise Date: 08/30/2013 Promise Time: 4:15PM

Creator: CHAD.GREEN

M13 Virginia Comm
619 6th Ave N

Virginia MN 55792
218/741-5181

Order Number M130004703
Invoice Number
Invoice Date 8/30/13
Salesperson BOB ROEHL
Customer PO
Page 1 of 1

Bill To Information:

CITY OF MT IRON C0007658
PO BOX 505
8586 ENTERPRISE DR S
MOUNTAIN IRON, MN 55768
(218) 748-7570 () - () -

Ship To Information:

CITY OF MT IRON
PO BOX 505
8586 ENTERPRISE DR S
MOUNTAIN IRON MN 55768
Ship Via Route 0

<u>Stock #</u>	<u>Description</u>	<u>Tech Id</u>	<u>Qty</u>	<u>Unit Price</u>	<u>F.E.T.</u>	<u>Extended</u>
99466	MICH XSNOPUS TS GS 17.5R25		5.00	\$1,999.00	0.00	9,995.00
E10	OTR MT/DMT		5.00	\$55.00	0.00	275.00
V650	650 VALVE STEM (STOCK ITEM)		5.00	\$14.95	0.00	74.75
OTRU03134	L-2 17.5R25 USED GRADER		-4.00	\$600.00	0.00	-2,400.00
OTRU03134	L-2 17.5R25 USED GRADER		-1.00	\$500.00	0.00	-500.00
	THE ADDED COST FOR ON-SITE INSTALLATION WOULD BE \$95.00					
SHOPSCML	ENVIRO FEE/SHOP S - COMM'L		1.00	\$16.50	0.00	16.50

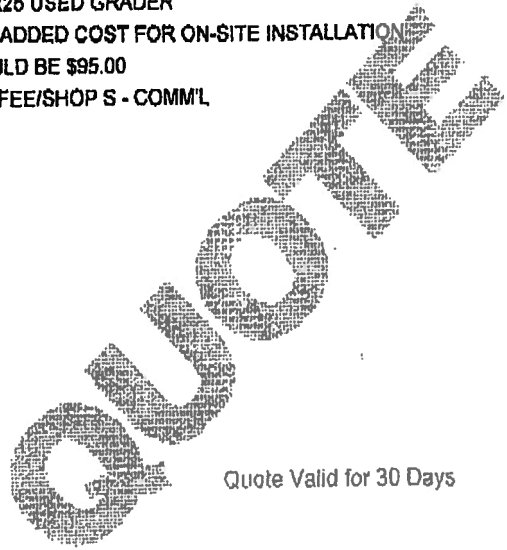

Quote Valid for 30 Days

<u>Tires</u>	<u>Parts</u>	<u>Labor</u>	<u>Other</u>	<u>Tax Rate</u>	<u>SubTotal</u>	<u>Sales Tax</u>	<u>FET</u>	<u>Order Total</u>
9,995.00	0.00	275.00	-2,808.75	6.88	\$7,461.25	\$ 492.92	\$ 0.00	\$ 7,954.17

08-29-'13 12:13 FROM-
POMP'S TIRE-VIRGINIA
201 NORTH HOOVER ROAD

T-463 P002/002 F-432

PAGE: 1

VIRGINIA, MN 55792

218/741-5562

CUSTOMER: CITY OF MT IRON
8586 ENTERPRISE DR S
7487597 CITY GARAGE
MT. IRON, MN 55768

CREATED BY CK
WORK: 218/748-7597 0
SALESMAN: CLAYTON KOSKELA
ESTIMATE DATE: 08/29/13

TERMS: 1 PMT DUE 10TH OF MON AFTR INV

PRODUCT	MECHANIC	QUANTITY	PRICE	F.E.T.	EXTENSION
17.5R25/* MICH X SNOPLUS MS T 994M66		5	1999.00		9995.00
13/14/15.5/17.5 DRY DISMT/MNT ODM1314D		5.00	85.00		425.00
GRADER VALVE 138L		5	10.00		50.00
used 17.5 Mich Sno plus PLTU		-5	350.00		-1750.00

*** PURCHASED FROM CUSTOMER ***

MERCHANDISE: 8295.00
LABOR: 425.00
SALES TAX: 690.59
ESTIMATE TOTAL: 9410.59

***** Valid for 30 days *****



Saint Louis County

8586 Enterprise Dr. S., Mountain Iron, MN 55768
(218) 748-7574

Sheriff Ross Litman

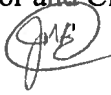
To: Mountain Iron Mayor and City Council
From: Sgt. John Backman 
Re: July 2013 Statistics
Date: September 5, 2013

The Mountain Iron Office of the St. Louis County Sheriff reports the below activity for the month of July 2013:

- 17 Disturbances (arguments, threats, unwanted persons, 911 hangup)
- 7 Public assists (roadside assistance/checks, patrol requests, vehicle unlocks)
- 9 Suspicious persons/vehicles/circumstances
- 3 Motor vehicle crashes
- 8 Welfare checks, suicide threats, neglect/abandoned persons, runaway/lost/missing
- 7 Fire & medical
- 3 Drug related calls
- 1 Alarms
- 3 Assaults
- 4 Damage to Property
- 13 Thefts
- 1 Burglary (or attempted)
- 10 Miscellaneous calls (civil/custody/property disputes, animal & traffic complaints, warrant/paper service)
- 31 Traffic Stops
- 7 Traffic Citations
- 4 DUI
- 13 Assists: 8 Sheriffs, 3 Virginia PD, 2 MSP, inside 2 Mt. Iron

This activity resulted in 4 custodial arrests.

COUNCIL LETTER 091613-IVG1

PUBLIC HEALTH AND SAFETY

EARLY WARNING SIRENS

DATE: September 12, 2013

FROM: Public Health and Safety Board

Craig J. Wainio
City Administrator

The public health and safety board is recommending that the City Council purchase two early warning sirens to be located in the residential areas of the City. This project is a coordinated effort with the City's of Virginia and Eveleth to provide maximum coverage for area residents. Primary control of the devices shall be located in the Virginia Police Department. The sirens are under State bid. City electrical crews will be able to handle some of the installation items thus reducing costs. It is recommended that the City Council authorize an capital improvement amount not to exceed \$40,000 for the purchase and installation of two early warning sirens.



QUOTATION
FEDERAL SIGNAL CORPORATION
Federal Warning Systems

Quotation No.: FWS **8613249**
 Reference quote no. on your order

Name Mountain Iron
 Co. Name Craig Wainio, Administrator
 Address 8586 Enterprise Drive South
 City, State, Zip Mountain Iron, MN 55768
 Phone No. 218-748-7570
 Fax No. cityadm@mtniron.com



Date 8/6/2013

Reference _____

CUSTOMER COPY SALESPERSON COPY OFFICE COPY

Item No.	Qty.	Federal Model/Part No.	Description	Net Cost Each	Total Cost
1	2	2001-130	130 db Rotating Mechanical Siren	\$6,100.00	\$12,200.00
2	2	DCFCTBDH	2-Way Digital DC Control/Battery Cabinet	4,975.00	9,950.00
3			Motorola CDM-750 Radio/Sensors		
4	2	2001TRBP	Transformer/Rectifier for AC/DC Operation	1,400.00	2,800.00
5	2	OMNI	3 db Gain Omnidirectional Antenna	275.00	550.00
6	2	AMB-P	Antenna Mounting Bracket – Pole	100.00	200.00
7	2	HTR4	4 Battery Warming Blankets	275.00	550.00
8	2	TKI2001ADCZ2	Turnkey Installation on 50 ft. Class 2 Wood	5,825.00	11,650.00
9			Poles/4 Deep Cycle Batteries		
10	1	MISC.	Shipping from Factory		1,300.00
11	1	MISC.	MN Sales Tax 6.875%		2,695.00
12					
13	1	TOTAL	TURNKEY SYSTEM		\$41,895.00
14					
15					
16					
17					
18					
19					
20					

Prices are firm for 30 days from the date of quotation unless shown otherwise. Upon acceptance, prices are firm for _____ (days / months). This quotation is expressly subject to acceptance by Buyer of all Terms stated on the reverse side hereof, and any exception to or modification of such Terms shall not be binding on Seller unless expressly accepted in writing by an authorized agent or Officer of Seller. Any order submitted to Seller on the basis set forth above, in whole or in part, shall constitute an acceptance by Buyer of the Terms on this and the reverse side hereof. Any such order shall be subject to acceptance by Seller in its discretion. If the total price for the items set forth above exceeds \$50,000 then this quotation IS ONLY VALID if countersigned below by a Regional Manager of the Signal Division, Federal Signal Corporation.

F.O.B. University Park, IL

EST. DEL. WT. _____

DELIVERY 6 – 8 Weeks (ARO)

TERMS Equipment: Net 30 Days Upon Shipment
Services: Net 30 Days Billed Monthly Upon Completion

FREIGHT TERMS See Line Item Above

BY: [Signature]
 FWS Sales Representative

ADDRESS: Federal Warning Systems, Inc.
1708 3rd Ave. SE
Rochester, MN 55904

BY: _____
 Federal Signal / Countersigned

TITLE: _____

Purchase order **MUST** be made out to:
 Federal Signal Corporation, Federal Warning Systems, 2645 Federal Signal Drive, University Park, IL 60488

2001-130 Siren

Features

- **130 dB(C) output**
- **Directional, rotating siren for maximum coverage**
- **Three distinct warning signals**
- **Full battery operation or battery back-up**
- **Maintenance-free sealed bearing motors**
- **Weather-resistant coating**
- **Ideal for outdoor warning**
- **5-year limited warranty**



The Federal Signal 2001-130 public siren is a high power, rotating, uni-directional outdoor warning siren that offers an anechoic certified signal strength of 130 dB(C) +/- 1 dB(C) at 100-ft. The high-decibel output provides maximum coverage with minimum installation cost. Radio activation can further minimize installation costs by eliminating the need for leased dedicated control lines.

The siren's projector produces a 60-degree projection of sound which rotates at 3 RPM and can produce three distinct warning signals: steady, wail and fast wail. The 2001-130 siren will supply a minimum of 15 minutes of full power output from its batteries after AC power loss. The siren controls are available with battery operation, AC operation, and AC operation with battery back-up, one-way and two-way radio control, wired or wireless ethernet, satellite/cellular or landline.

Ideally suited to provide warning for hazardous weather conditions, fires, floods, chemical spills and other types of emergencies, the 2001-130 siren is a perfect choice to protect any community.



FEDERAL SIGNAL
Safety and Security Systems

Advancing security and well being.

2001-130 Siren Specifications

Power Requirements*

Siren Motor	48V (DC or full wave rectified AC) 110A (nom.)
Rotator Motor	48V (DC or full wave rectified AC) 1A (nom.)

Wiring

Siren Motor	2 AWG
Rotator Motor	12 AWG

Motor Type

Siren	Series wound DC 6 Hp
Rotator	Permanent magnet DC 1/8 Hp

Signal Information

Signal	Frequency Range	Sweep Rate
Steady	790 Hz	N.A.
Wail	470-790 Hz	10 sec.
Fast Wail	600-790 Hz	3.5 sec.
Signal Duration	3min. std. (programmable)	
Signal Output (SPL)	130 dB(C) +/- 1 dB(C) at 100' (30.5 m) 6400 feet Effective Range at 70dBC	
Rotation	3 RPM	

Dimensions

Height x Width x Depth	55" x 37" x 41" 140cm x 94cm x 10cm
------------------------	--

Weight

Shipping Weight	450 lbs. (205 kg)
-----------------	-------------------

Environmental

Operating Temperature	-30°C to +60°C**
-----------------------	------------------

* Power requirements refer to the power supplied by the batteries or optional AC operation through 2001TRB.

** The siren can operate throughout this temperature range provided that battery temperature is maintained at 18°C or higher.

Ordering Information*

Siren Motor	Rotating electro-mechanical Siren 130 dB(C) +/- 1dB(C), 48VDC, pole mount included
2001AC ¹	AC operated motor control, 208 or 220/240VAC (specify voltage) NEMA 3R control cabinet, two 48VDC contactors and transformer/rectifier, 182 lbs. 53 kg
2001DC ^{1,2}	120VAC motor control, NEMA 4 control cabinet, four chargers, two 48VDC contactors and NEMA 3R battery cabinet. 224 lbs. 102 kg

Landline Option

2001HR	Rotator holding relay for use with external timer
--------	---

* 2001-130 Siren requires a Federal Controller such as FC or DFCB (See controller product literature)

¹ For use with Electro-mechanical sirens. Antenna and cable are not included with any radio activation control and must be purchased separately. (See your sales representative)

² Batteries not included.

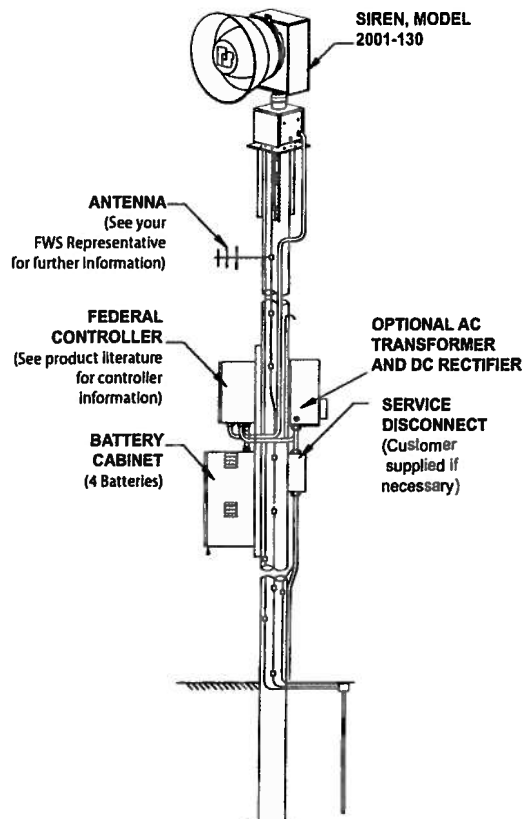

FEDERAL SIGNAL
Safety and Security Systems
Advancing security and well being.

DCFCTBD DC Two-Way Digital Controller

Features

- **Two-way siren controller for 48VDC sirens**
- **Two-way radio control and status monitoring**
- **AFSK two-way signaling format**
- **Simultaneous single-tone, two-tone sequential, and DTMF, EAS, and POCSAG decoding.**
- **Push buttons for local activation**
- **UL Listed for general signaling**

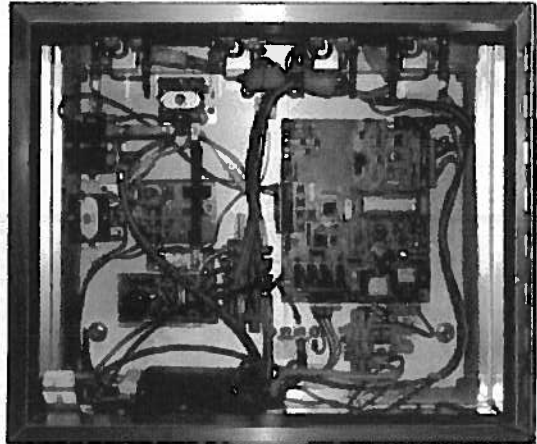

The Federal Signal DCFCTBD is a two-way digital, battery-operated status monitoring siren controller for use with the Federal Signal 2001-130 siren and Eclipse siren series. The controller interfaces with an off-the-shelf two-way radio transceiver and communicates to the base control via AFSK signaling. In addition to AFSK, the controllers will simultaneously decode any combination of single-tone, two-tone sequential, DTMF, POCSAG and EAS formats for activation. This makes the two-way controller compatible with virtually any existing siren control system.

All DCFCTBD models come equipped with four independent relay outputs that can be programmed to activate with various codes. There are four landline inputs and four local push buttons for activation, plus reset. Activation codes, relay timing, and optional warning sounds are programmed into the unit through a standard RS232 serial port or over-the-air from the central control point.

The DCFCTBD offers six user programmable functions in addition to the five pre-set functions: arm, disarm, report, growl test and master reset. The controller includes the necessary sensors and wiring to supply information on the following areas of operation: AC power status, communications status, low battery status, intrusion, siren activation, current intrusion, siren rotation and local activation.

DCFCTBD DC Two-Way Digital Controller Specifications

Electrical

AC supply voltage	120 VAC @ 4.0 Amps
Current Draw	+/- 10%, 50/60 Hz, maximum standby current
Power Supply	6A @ 13.3VDC
Battery Backup	48VDC
Current Draw	< .2 Amps in standby

Serial Ports

Serial Port Protocol	RS232C 1200, N, 8, 1
----------------------	----------------------

Transceiver

Programmable Frequency	Power Out and Private Line options. For further details consult the Motorola® product Manual.
------------------------	---

Signaling Format

AFSK	1200 baud, MSK (Minimum Shift Key) modem type Useable decode sensitivity: 12dB SINAD (min.)
DTMF	3-12 standard DTMF characters

Two-Tone Sequential

Frequency Range	282 Hz - 3000 Hz (non-CTCSS) 400 Hz - 3000 Hz (CTCSS)
-----------------	--

Tone Timing	.5 sec - .25 sec min., 8 sec max
-------------	----------------------------------

Intertone Gap	400ms (maximum)
---------------	-----------------

Tone Accuracy	+/- 1.5%
---------------	----------

Tone Spacing	5.0% preferred, 3% min.
--------------	-------------------------

Single Tone

Frequency Range	282 Hz - 3000 Hz
-----------------	------------------

Tone Timing	0.5 sec. - 8 sec maximum
-------------	--------------------------

Tone Accuracy	+/- 1.5%
---------------	----------

Tone Spacing	5.0% preferred, 3% min.
--------------	-------------------------

EAS	Supports standard EAS codes and wildcards
-----	---

POCSAG	Supports binary AFSK 512 Baud numeric messages.
--------	---

Relay Outputs

4 relay outputs	SPST
-----------------	------

Contact Rating	(4 relays standard) 5A @ 28VDC – 5A @ 240VAC
----------------	--

Audio Output

Output Voltage	>2V Peak to Peak
----------------	------------------

Maximum Load	8 Ohms
--------------	--------

Total Harmonic Distortion	<10% @ 1kHz Sinewave
---------------------------	----------------------

Environmental

Operating Temperature	-30°C to 65°C
-----------------------	---------------

Controller Dimensions (with battery cabinet)

HxWxD	62.5" x 23.5" x 16.94" 1588mm x 597mm x 430mm NEMA 4X Rated
-------	--

Battery Cabinet Dimensions

HxWxD	18" x 28" x 15.19" 457mm x 711mm x 386mm Vented NEMA 4X Rated
-------	--

Shipping Weight

Approx. Shipping Weight	300 lbs. (136.36 kg)
-------------------------	----------------------

Actual Weight	234 lbs. (106.3 kg)
---------------	---------------------

2001TR: AC Primary Operation

Operating Voltage	208/220/240 VAC single phase
-------------------	------------------------------

Current Requirements	30 Amps (approx.)
----------------------	-------------------

Dimensions	23" x 11" x 10" (584mm x 279mm x 254mm)
------------	---

Product Weight	150 lbs. (68.2 kg)
----------------	--------------------

Order information

DCFCTBD ^{1,2}	Two-way Federal Controller
------------------------	----------------------------

DCFCTBDH ^{1,2}	Two-way Federal Controller, high band 136-174 MHz
-------------------------	---

DCFCTBDU ^{1,2}	Two-way Federal Controller, UHF band 403-470 MHz
-------------------------	--

DCFCTBD-IP ^{1,3}	IP-enabled two-way electro-mechanical controller
---------------------------	--

Options

FSPWARE	Federal Programming Software (Non-Digital Applications)
---------	--

SFCDWARE	Federal Commander Digital Software (See literature for details)
----------	--

Q-DC-IP ^{1,3}	Retrofit kit to upgrade existing controller to IP
------------------------	---

ES-PROG-DTMF	Two-Way DTMF Programming
--------------	--------------------------

¹ For use with 2001-130 and Eclipse siren series.

² Antenna and cable are not included with radio activation control and must be ordered separately.

³ Broadband radio and Codespear software sold separately.

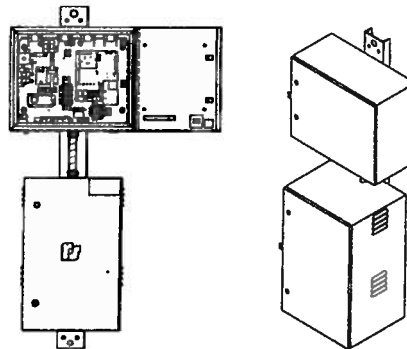

COUNCIL LETTER 091613-IVH1

PERSONNEL COMMITTEE

LEAD POSITION

DATE: September 12, 2013

FROM: Personnel Committee

Craig J. Wainio
City Administrator

The personnel committee is recommending that the City Council approve the enclosed lead journeyman lineman position analysis and list it as job class 28 with a hourly rate of \$29.70. Also it is recommended that staff is authorized to post this position internally as outline in the AFSCME Agreement. This position is only for internal candidates and will not be open to individuals outside the organization.

CITY OF MOUNTAIN IRON POSITION ANALYSIS

POSITION TITLE: Lead Journeyman Lineman/Journeyman Lineman

SUPERVISOR: Director of Public Works

PRIMARY OBJECTIVE OF POSITION:

The primary objective of this position is to lead and perform skilled work in connection with the operation, maintenance and construction of the electric system.

RESPONSIBILITIES:

- ◆ Install, repair and maintain the electrical distribution system including building services, utility poles and related hardware.
- ◆ Adjusts, repairs, replaces electrical and related mechanical equipment and parts.
- ◆ Locates trouble sources in the electrical system or equipment and inspects installations for compliance with codes and ordinances.
- ◆ Instruct personnel in duties, safe work practices, use and care of tools and equipment.
- ◆ Assign tasks, projects and duties required.
- ◆ Works with Supervisor to set up on call schedule.
- ◆ Operates loader, bucket truck, other City equipment and vehicles as required
- ◆ Oversee, work with and mentor any electrical apprentices the City may have.
- ◆ Perform other duties of the City such as snow plowing and other construction work.
- ◆ Must be available for on call and callout duty as outlined in City policy. Must be a permanent resident within the callout response time area
- ◆ Performs all duties contained in the Journeyman Lineman's Position Analysis.
- ◆ Other duties as apparent or as delegated.

KNOWLEDGE, SKILLS AND ABILITIES:

- ◆ Ability to read and interpret electrical diagrams
- ◆ Ability to use and maintain required tools and equipment.
- ◆ Ability to climb poles, work at heights and to perform strenuous physical activity.
- ◆ Ability to take a leadership role when supervisor is unavailable.
- ◆ Ability to interpret and manage competing priorities under time constraints.
- ◆ Strong ability to communicate effectively both orally and in writing.
- ◆ Knowledge of methods and practices of the electrical trade with an emphasis on line work.
- ◆ Knowledge of electrical codes, ordinances and safety requirements.
- ◆ Knowledge of the basic operation and maintenance of the various City equipment.

TRAINING AND EXPERIENCE:

- ◆ AA/AS, Technical College Degree in related field or equivalent, training in the related field preferred or minimum of five years experience with at least three at a supervisory level.
- ◆ Class B Commercial Drivers License.
- ◆ Journeyman Lineman's Certification.
- ◆ Experience at as a supervisor.

**COUNCIL LETTER 091613-VIA
ADMINISTRATION
RESOLUTION NUMBER 35-13**

DATE: September 12, 2013
FROM: Craig J. Wainio
City Administrator

Resolution Number 35-13 declares the cost of the Bluebell and Daffodil Avenue project and orders the preparation of an assessment role. Once the assessment role is completed it will be presented to the City Council and a Public Hearing will be scheduled on the proposed assessments.



CITY OF MOUNTAIN IRON

"TACONITE CAPITAL OF THE WORLD"

PHONE: 218-748-7570 • FAX: 218-748-7573 • www.mtniron.com
8586 ENTERPRISE DRIVE SOUTH • MOUNTAIN IRON, MN • 55768-8260

RESOLUTION NUMBER 35-13

DECLARING COST TO BE ASSESSED, AND ORDERING PREPARATION OF PROPOSED ASSESSMENT

WHEREAS, costs have been determined for Improvement Number 11-06, the improvement of Bluebell Avenue and Daffodil Avenue between the centerline of Unity Drive and the centerline of Jasmine Street by reconstruction or overlayment and the contract price for such improvement is \$123,968.00, and the expenses incurred in the making of such improvement amount to \$31,897.38 so that the total cost of the improvement will be \$155,865.38.

NOW THEREFORE, BE IT RESOLVED BY THE CITY COUNCIL OF MOUNTAIN IRON, MINNESOTA:

1. The portion of the cost of such improvement to be paid by the City is hereby declared to be \$38,966.35 and the portion of the cost to be assessed against benefited property owners is declared to be \$116,899.03.
2. Assessments shall be payable in equal annual installments extending over a period of 10 years, the first of the installments to be payable on or before the first Monday in January, 2014, and shall bear interest at the rate of 8 percent per annum from the date of the adoption of the assessment resolution.
3. The City Administrator, with the assistance of the city engineer, shall forthwith calculate the proper amount to be specially assessed for such improvement against every assessable lot, piece or parcel of land within the district affected, without regard to cash valuation, as provided by law, and he shall file a copy of such proposed assessment in his office for public inspection.
4. The City Administrator shall upon the completion of such proposed assessment, notify the City Council thereof.

DULY ADOPTED BY THE CITY COUNCIL THIS 16th DAY OF SEPTEMBER, 2013.

ATTEST:

Mayor Gary Skalko

City Administrator

COUNCIL LETTER 091613-VIB

ADMINISTRATION

LICENSE AGREEMENT

DATE: September 12, 2013

FROM: Craig J. Wainio
City Administrator

Enclosed, please find a real estate license agreement between the City and Minntac. Basically this agreement maintains open access to the Renewable Energy Park off of Mineral Avenue during the period in which the new County Road 102 will be under construction. Staff and the City Attorney have review this license and recommend it approval.

REAL ESTATE LICENSE AGREEMENT

This REAL ESTATE LICENSE AGREEMENT (this “**License**”) is made as of this ____ day July 2013, by and between UNITED STATES STEEL CORPORATION, a Delaware corporation (“**USS**”), and the CITY OF MOUNTAIN IRON, a body public, corporate, and politic and a political subdivision under the laws of the State of Minnesota (the “**City**”).

WITNESSETH:

WHEREAS, the Mt. Iron Economic Development Authority, a body public, corporate, and politic and a political subdivision under the laws of the State of Minnesota (the “**EDA**”), which is an affiliate of the City, owns certain real estate in the City of Mountain Iron, St. Louis County, Minnesota identified on “**Exhibit A**” attached hereto and incorporated herein by reference (the “**Property**”);

WHEREAS, the EDA has previously constructed and currently maintains on the Property a gravel roadway (the “**Old Roadway**”) to enable the City and the EDA and each of their employees, invitees, and licensees and members of the public (the “**Benefited Parties**”) to access adjacent property owned by the EDA (the “**Adjacent Property**”);

WHEREAS, USS has undertaken a project to relocate a portion of County State Aid Highway 102 from its current location to a new location (the portions of such highway in its new location, “**New 102**”), a portion of which will be on the Property;

WHEREAS, pursuant to a “Real Estate Purchase Agreement” (the “**EDA Agreement**”), the EDA has agreed to sell the Property to USS to enable USS to construct New 102 thereon;

WHEREAS, the activities to construct New 102 will render the Old Roadway unusable;

WHEREAS, upon completion of New 102, USS will dedicate New 102 to the County of St. Louis (the “**Dedication**”), at which time the Benefited Parties will be entitled to access the Adjacent Property via New 102;

WHEREAS, from the time at which USS’ construction activities render the Old Roadway unusable until the Dedication of New 102, the Benefited Parties will require alternative access to the Adjacent Property; and

WHEREAS, the City desires to obtain from USS, and USS has agreed to grant to the City, a license to the portion of the Property to be reasonably designated by USS from time to time during the course of constructing New 102 (which may or may not be the future location of New 102), on which USS will construct a temporary roadway (the “**Temporary Roadway**”) to enable the Benefited Parties to access the Adjacent Property.

NOW, THEREFORE, in consideration of all the covenants, terms, and conditions herein contained, and intending to be legally bound hereby, the parties hereto agree as follows:

1. **Grant of License; Private License; Reservation of Rights; Exclusivity; Relocation.**

(A) The foregoing recitals are hereby incorporated into this License by reference as if fully set forth below.

(B) Upon and subject to the terms hereof, USS hereby grants to the City a limited, revocable, non-exclusive right and license to access and use the Temporary Roadway during the term hereof for the following purpose, and the City agrees to use the Temporary Roadway only for this purpose and for no other purpose whatsoever: for the Benefited Parties' pedestrian and vehicular ingress, egress, and regress to and from the Adjacent Property from and to the nearest public roadway and for the City to maintain the Temporary Roadway as required hereunder.

(C) The rights granted herein are limited to the Benefited Parties for the purposes stated herein and do not constitute a dedication of the Temporary Roadway.

(D) USS hereby does, and the City hereby acknowledges and agrees that USS does, reserve any and all right, title, and interest in and to the Temporary Roadway and the remainder of the Property, including, the right to use the Temporary Roadway for any and all purposes whatsoever; and the right to mortgage, pledge, hypothecate, assign, lease, or otherwise transfer any or all of the Property or USS' right therein. Further, the City acknowledges and agrees that this License is subject to any and all highway, railroad, and other public or private rights or easements, existing in or across the Temporary Roadway or any part thereof, and to the rights of any person or other person who may have an interest in the Property, including any minerals therein.

(E) The City hereby acknowledges and agrees that the rights hereunder are non-exclusive and that, among other rights reserved by USS, USS retains the right to grant one or more other parties the right to access and use the Temporary Roadway during the term hereof.

(F) USS reserves the right, at any time and for any reason in USS' discretion, to relocate the location of the Temporary Roadway.

2. **Term.** The rights granted herein shall begin immediately following the closing of the EDA's sale of the Property to USS pursuant to the EDA Agreement and shall terminate on the effective date of the County of St. Louis' formal acceptance USS' Dedication of New 102.

3. **Payments (Rent and Damages).**

(A) USS, the City, and the EDA acknowledge and agree that this License is being entered into pursuant to and as a condition to the EDA Agreement and other agreements, and that no additional consideration is being required from the City or the EDA to USS.

(B) The City shall pay USS for all damages to the Property or surrounding area.

4. **Termination; Default.** If the City fails to perform any of its covenants or obligations hereunder, and such failure continues for ten (10) days after USS gives the City written notice of said failure, then this License and all of the rights granted hereby shall forthwith cease and terminate as of such date without any further notice or other action on the part of USS.

5. Representations, Warranties, and Covenants.

(A) The City covenants that its and its contractors' use of and activities on the Temporary Roadway shall at all times comply with all applicable present and future laws, ordinances, permits, rules, and regulations enacted by any federal, state, county, or municipal governmental agency having jurisdiction or control over said use and activities (including reclamation and/or pollution, environmental or otherwise) occurring upon the Temporary Roadway from the City's activities thereon. The City further agrees, if necessary, to obtain all permits for its activities hereunder at its sole expense and to comply with all such permits. The City shall provide USS with copies of said permit(s) and any and all associated documents, maps, and plans.

(B) The City covenants and agrees that the City shall not grant, create, suffer, or permit any claim, encumbrance, easement, restriction, mechanic's or materialmen's liens, or other charge or exception to title to be placed on the Property or any other property of USS, whether by reason of any work, labor, services, materials, or equipment supplied or claimed to have been supplied to the City or any contractor or subcontractor of the City, or otherwise. If any such matter is filed against the Property or any other property of USS arising out of or relating to this License, then the City shall promptly, after notice of filing, either (i) cause the same to be discharged of record by deposit in court or by the issuance of a bond; or (ii) furnish USS with indemnification or other security against loss or damage arising from the lien in form and substance satisfactory to USS. If the City learns of any claim or action pertaining to any such liens with respect to the Property or any other property of USS, the City shall give prompt notice of the same to USS at the address identified herein.

(C) During the periods of time in which USS is actively constructing New 102 (i.e., the construction season of each year), USS shall maintain the Temporary Roadway. During the periods of time in which USS is not actively constructing New 102, the City covenants that it shall keep the Temporary Roadway in good repair and in a safe, neat, and orderly condition and so maintain, use, and occupy the same as to protect life and property and so as not to create any public or private nuisance or damage or injury to any adjacent premises or to any persons or property thereon. Without limiting the generality of the foregoing, during the times in which the City is required to maintain the Temporary Roadway, the City shall maintain the Temporary Roadway during the winter months in the same manner in which the City maintains public roadways within the City's jurisdiction (including, without limitation, plowing snow from the Temporary Roadway and applying sand or other substances thereon to ensure vehicular traction thereon). In performing such maintenance, the City shall ensure that its employees or contractors do not unreasonably damage construction work performed by or for USS relating to the construction of New 102. USS and the City shall communicate with each other to coordinate the dates on which the maintenance obligations hereunder are to be transferred at the beginning and end of each construction season.

(D) The City covenants that the City's and/or the City's contractors' occupancy or use of the Temporary Roadway shall not unreasonably interfere with USS', or any other licensee's, tenant's, invitee's, or other occupant's, use or occupancy of (and the City shall not, and shall not permit its contractors to, in any manner prevent USS' or any other licensee's, tenant's invitee's or other occupant's access to or use or occupancy of) the Temporary Roadway or the Property.

(E) USS retains the right to inspect the Temporary Roadway to ensure the City's compliance with its covenants hereunder.

6. Disclaimers of Warranties; Limitations of Liability.

(A) **Disclaimers of Warranties.** The City represents, warrants, acknowledges, and agrees that (i) it has examined and inspected the Property and that the City has determined that the Property is suitable for the City's uses contemplated hereunder, (ii) USS has not undertaken and will not be obligated to maintain the Temporary Roadway in any manner whatsoever, including, without limitation, maintaining the Temporary Roadway in a safe and habitable condition, (iii) USS' EXPRESS WARRANTIES HEREIN ARE ITS EXCLUSIVE WARRANTIES AND USS MAKES NO REPRESENTATIONS OR WARRANTIES REGARDING THE TEMPORARY ROADWAY, OR ANY OTHER MATTER WHATSOEVER, AND (iv) EXCEPT FOR USS' EXPRESS WARRANTIES HEREIN: (a) THE TEMPORARY ROADWAY ARE PROVIDED "AS-IS", "WHERE-IS", AND "WITH ALL FAULTS"; (b) TO THE FULLEST EXTENT PERMITTED BY LAW USS HEREBY DISCLAIMS ALL WARRANTIES, EXPRESS OR IMPLIED, WHETHER BY STATUTE, COMMON LAW, COURSE OF DEALING OR PERFORMANCE, TRADE USAGE, OR OTHERWISE, INCLUDING WARRANTIES OF MERCHANTABILITY AND FITNESS FOR A PARTICULAR PURPOSE.

(B) **Limitation of Liabilities.** (i) Notwithstanding any term or provision herein to the contrary, the City acknowledges and agrees that neither USS nor any party acting by, through, or for USS or on USS' behalf shall have any personal liability whatsoever. (ii) IN NO EVENT SHALL USS BE LIABLE FOR ANY CONSEQUENTIAL, INCIDENTAL, SPECIAL, PUNITIVE, OR OTHER INDIRECT DAMAGES, HOWEVER CAUSED, INCLUDING BUSINESS INTERRUPTION OR LOST PROFITS.

7. Insurance.

(A) During the entire term hereof, the City will obtain and maintain in full force and effect, and will cause its contractors to maintain in full force and effect, insurance coverage in accordance with the terms and provisions outlined in Attachment "I" attached hereto and incorporated herein. The City further agrees that before it or any of its contractors visits or occupies the Temporary Roadway that it shall provide USS with proof of the aforementioned insurance coverage in a form suitable to USS.

(B) The obligations set forth in this Section and in Attachment "I" shall survive the expiration or termination of this License as to any matters that occurred during or resulted from the term of this License.

8. Indemnification; Defense.

(A) The City, for itself and its successors and assigns, agrees to and hereby does indemnify and hold harmless USS, its parents, subsidiaries, affiliates, and divisions, and each of their shareholders, members, and partners, and each of their officers, directors, employees, agents, representatives, and contractors, and each of their heirs, personal representatives, successors, and assigns (the "**Indemnified Parties**") from and against any and all claims,

actions, losses, liabilities, obligations, costs, expenses, fines, fees, verdicts, judgments, or any other damages, of any nature whatsoever, whether arising from contract, tort, or otherwise, including, without limitation, reasonable attorney's fees, defense costs, investigation expenses, discovery costs, court costs, and all other expenses, arising from or relating to: (i) the City's performance or nonperformance of any term or condition of this License; (ii) bodily injury, illness, disease, death, property damage, or loss of use, maintenance, cure, profit, or wages occurring on or caused by occurrences on the Temporary Roadway; (iii) the City's violation of any ordinance, permit, order, law, regulation, statute, legislation, judgment, or decree; and/or (iv) any use by the City or the Benefited of the Temporary Roadway or any common area or any other property of USS, including the City's or the Benefited Parties' presence, occupancy or use of the Temporary Roadway prior to the Commencement Date and after the termination of this License, and in any and all events, including, without limitation, (a) any acts or omissions of the City's or the EDA's agents, employees, managers, visitors, contractors, subcontractors, lessees, sublessees, invitees, licensees, customers, concessionaires or assignees and (b) any and all acts or omissions, including, without limitation, the actual or alleged negligence of one or more of the Indemnified Parties, whether or not occurring on the Temporary Roadway and whether or not such acts or omissions cause or result in bodily injury, illness, disease, death, property damage, or loss of use, maintenance, cure, profit, or wages of employee(s) of USS or the City (all of the foregoing, the "**Indemnified Matters**"). The City agrees that the indemnity provided by this paragraph is unlimited and the City waives any and all statutory tort limitations provided for in Minnesota Statutes as such limits pertain to USS. The City retains the statutory tort limitations as such limits apply to the City's liability to other third parties.

(B) The City agrees to defend each of the Indemnified Parties, at the City's sole cost and expense, in any litigation, action, arbitration, mediation, or other legal or administrative proceeding against one or more of the Indemnified Parties arising from or relating to any of the Indemnified Matters; provided that the Indemnified Party shall have the right to approve or disapprove of (i) counsel chosen by the City to represent the Indemnified Party in any such matter, and in the event counsel chosen by the City is unacceptable to the Indemnified Party, the Indemnified Party may engage its own counsel, at the City's sole cost and expense, to represent the Indemnified Party in such matter, (ii) defenses, counterclaims, or cross claims to be raised or made by or on behalf of the Indemnified Party, and (iii) whether or not to settle any such matter.

(C) The terms of this Section shall survive the expiration or termination hereof.

9. Environmental Laws; Hazardous Substances.

(A) **Definitions.** For the purposes of this Section: (i) "**Environmental Laws**" means all federal, state, and local environmental health or safety laws, rules, regulations, codes, ordinances, orders, and rules of common law now or any time hereafter in effect, including, without limitation, requirements of governmental authorities regulating, relating to, or imposing liability for, or standards of conduct for, any Hazardous Material, including, without limitation, the Comprehensive Environmental Response, Compensation and Liability Act and any so-called "Superfund" or "Superlien" law; and (ii) "**Hazardous Material**" means any hazardous, toxic, or dangerous substance, waste, or material, whether in solid, liquid, or gaseous form, including, without limitation, asbestos, petroleum products, and any and all substances and materials defined as hazardous, toxic, or dangerous in (or for purposes of) any Environmental Law.

(B) Covenant. The City covenants that, except in compliance with Environmental Laws, (i) no inflammable, explosive, or dangerous fluids or substances shall be used or kept on or about the Temporary Roadway or any other property of USS, (ii) neither the City nor any of the Benefited Parties shall, without USS' prior written consent, bring, introduce, install, store, maintain, use, spill, remove, release, or dispose of any Hazardous Material on or about the Temporary Roadway or any other property of USS, (iii) the City and the Benefited Parties shall, and its use of the Temporary Roadway shall, comply with all Environmental Laws, and (iv) the City will immediately notify USS of (a) any violation of any Environmental Law, (b) receipt of any notice or warning from, and/or any visit by, any environmental governmental agency for any reason whatsoever.

(C) Survival. The terms of this Section shall survive the expiration or earlier termination hereof.

10. Miscellaneous.

(A) **Entire Agreement; Binding Effect**. This License, including any terms and conditions incorporated herein or attached hereto, constitutes the entire agreement between the parties, and there are no representations, oral or written, that have not been incorporated herein. This License shall be binding upon and inure to the benefit of the successors and assigns of the parties hereto. No representation, inducement, promise, understanding, condition, or warranty not set forth herein has been made or relied upon by either party.

(B) **Amendment**. This License may be amended, renewed, extended, or canceled only by a written instrument executed on behalf of each of the parties hereto by an authorized representative of each party, and neither party shall, at any time or in any way, assert or contend that any amendment, extension or cancellation of this License (or any part or parts, including this Section) has been made other than by a written instrument so executed.

(C) **Assignment**. The City may not transfer or assign its rights and obligations under this License, in whole or in part, without the prior written consent of USS. Additionally, USS and the City do not intend to, nor do they, create any rights in any third party or person not a signatory to this License.

(D) **Notice**. Any notice that may at any time be required to be given hereunder shall be deemed to have been properly given if personally hand delivered to the other party, or if sent by United States first class registered or certified mail, postage prepaid, or by facsimile transmission, addressed as follows:

If to USS:

Minnesota Ore Operations

Attn: General Manager

Facsimile: (____) ____-____

With a copy to:
United States Steel Corporation
600 Grant Street
Pittsburgh, PA 15219-2800
Attn: Attorney – Real Estate

Facsimile: (412) 433-2912

If to the City:

Facsimile: (____) ____ - _____

With a copy to:

Facsimile: (____) ____ - _____

All notices shall be effective when received by the party to whom addressed. Either party may by such a notice to the other party designate a different addressee to whom or address to which any such notice shall be sent.

(E) Construction; Venue. This License shall be governed by and performed in accordance with the laws of the state in which the Property is located, without giving effect to its conflicts of law provisions. Each party, for itself and its heirs, representatives, successors, and assigns, hereby irrevocably consents to the exclusive jurisdiction of the federal and state courts sitting in or for the county in which the Property are located for the resolution of any conflicts arising hereunder, and each agrees that such courts are the proper and convenient venue and waive any right to object to such venue as being inconvenient or otherwise.

(F) Counterpart. This License may be signed in one or more counterparts, and by facsimile transmission, all of which shall be treated as one and the same original agreement. Each party shall provide an executed copy to the other.

(G) Severability. If any provision of this License is found to be invalid or otherwise unenforceable in any court of competent jurisdiction, the allegedly invalid or unenforceable provision shall be deemed valid and enforceable to the maximum extent permitted by law and shall be deemed to be amended to the minimum extent necessary to make it valid and enforceable in such jurisdiction, and the alleged invalidity and/or unenforceability in such jurisdiction shall not affect the validity or enforceability of any other provision hereof in such jurisdiction or the validity or enforceability of the allegedly invalid and/or unenforceable provision, or of any other provision hereof, in any other jurisdiction.

(H) Survival. The following provisions hereof shall survive the expiration or earlier termination hereof: (i) all provisions hereof that specifically state that they shall survive the expiration or earlier termination hereof, and (ii) all provisions that, by their nature, should be reasonably anticipated by the parties to survive the expiration or earlier termination hereof.

(I) Recordation. Neither party shall be permitted to record this License in the official records of any jurisdiction, including the jurisdiction in which the Property is located.

IN WITNESS WHEREOF, the parties have caused this License to be executed as of the date(s) indicated herein.

USS
United States Steel Corporation,
a Delaware corporation

By: _____

Name: _____

Title: _____

THE CITY
The City Of Mountain Iron,
a body public, corporate and politic and a political
subdivision under the laws of the State of Minnesota

By: _____

Name: _____

Title: _____

ATTACHMENT "I" INSURANCE REQUIREMENTS

Contractor shall procure and maintain, at its own expense, and shall require its Subcontractor(s), if any, to procure and maintain for the duration hereunder the insurance coverage meeting or exceeding the requirements set forth below:

1. Minimum Scope of Insurance -- Coverage shall be at least as broad as the following:

A. Commercial General Liability Insurance: Shall be written on ISO occurrence form CG 00 01 (or a substitute form providing equivalent coverage) and shall cover liability arising from premises, operations, independent contractors, products-completed operations, personal injury and liability assumed under an insured contract (including the tort liability of another assumed in a business contract). If a 1973 edition ISO form must be used by the insurer, the broad form comprehensive general liability (BFCGL) endorsement shall be included. Additionally, the policy shall not contain a sunset provision, commutation clause or any other provision which would prohibit the reporting of a claim and the subsequent defense and indemnity that would normally be provided by the policy. The policy of insurance shall contain or be endorsed to include the following:

- (i) Premises/Operations;
- (ii) Products/Completed Operations;
- (iii) Contractual;
- (iv) Independent Contractors;
- (v) Broad Form Property Damage;
- (vi) Personal and Advertising Injury;
- (vii) Separation of Insureds (Severability of Interest);
- (viii) The policy shall be endorsed using ISO form CG 20 10 11 85 (or a substitute form providing equivalent coverage) so as to include United States Steel Corporation (hereinafter "USS") and its affiliates, including all units, divisions and subsidiaries as Additional Insureds on a primary and non-contributory basis. The coverage shall contain no special limitations on the scope of protection afforded to said Additional Insured.
- (ix) Waiver of subrogation shall be provided to the benefit of all Additional Insureds, as aforesaid.
- (x) No XCU (explosion, collapse, underground) exclusion.

- (xi) For any claims related herein, the Contractor's and its Subcontractor's insurance shall be primary and non-contributory respecting the aforesaid Additional Insureds. Any insurance or self-insurance maintained by USS shall be in excess of the Contractor's and its Subcontractor's insurance and shall not contribute with it.
- (xii) The policy shall not contain any provision, definition, or endorsement which would serve to eliminate third-party action over claims.
- (xiii) The policy shall not be endorsed to include ISO endorsement form CG 24 26 or any similar provision.
- (xiv) Self-funded or other non-risk transfer insurance mechanisms are not normally acceptable to USS. If the Contractor and/or Subcontractor has such a program, full disclosure must be made to USS prior to any consideration being given.

SPECIAL NOTE: If watercraft are used in connection with operations, evidence of watercraft liability coverage is required, subject to USS's approval.

B. Automobile Liability Insurance: As specified by ISO form number CA 0001, Symbol I (any auto), with an MCS 90 endorsement and a CA 99 48 endorsement attached if hazardous materials or waste are to be transported. This policy shall be endorsed to include USS and its affiliates, including all units, divisions and subsidiaries as Additional Insureds, and to include waiver of subrogation to the benefit of all Additional Insureds, as aforesaid.

C. Workers' Compensation Insurance: As required by the State or Commonwealth in which work is being done, and in accordance with any applicable Federal laws, including Employer's Liability Insurance and/or Stop Gap Liability coverage as per below limits. Where not otherwise prohibited by law, this policy shall be endorsed to include waiver of subrogation to the benefit of USS and its affiliates, including all units, divisions and subsidiaries.

D. Employer's Liability and/or Stop Gap Liability Coverage: Coverages per accident, disease-policy limit, and disease each employee.

Note Relating to Items C. and D. Above - Operations on or near water require the following: Statutory Workers' Compensation/USL&H coverage, Employer's Liability including Maritime Employer's Liability coverage.

E. Errors and Omissions Professional Liability Insurance (If made applicable by USS): Coverage should be for a professional error, act or omission arising out of the Contractor's performance of work hereunder. The policy form may not exclude coverage for bodily injury, property damage, claims arising out of laboratory analysis, pollution or the operations of a treatment facility, to the extent these items are applicable under the scope of work hereunder. This policy shall be endorsed to include waiver of subrogation to the benefit of USS and its affiliates, including all units, divisions and subsidiaries. If coverage is on a claims-made form, Contractor shall maintain continuous coverage or exercise an extended discovery period for a period of no less than five (5) years from the time that the work hereunder has been completed.

F. Environmental Impairment Insurance (If made applicable by USS): Covering damage to the environment, both sudden and non-sudden, caused by the emission, disposal, release, seepage, or escape of smoke, vapors, soot, fumes, acids, alkalis, toxic chemicals, liquid or gases, waste materials or other irritants, contaminants or pollutants, into or upon land, the atmosphere or any water course or body of water; or the generation of odor, noises, vibrations, light, electricity, radiation, changes in temperature, or any other sensory phenomena. Such insurance shall contain or be endorsed to include:

- (i) Property damage, including loss of use, injury to or destruction of property;
- (ii) Cleanup costs which shall include operations designed to **analyze, monitor,** remove, remedy, neutralize, or clean up any released or escaped substance which has caused environmental impairment or could cause environmental impairment if not removed, neutralized or cleaned up.
- (iii) Personal injury, which shall include bodily injury, sickness, disease, mental anguish, shock or disability sustained by any person, including death resulting therefrom.
- (iv) USS and its affiliates, including all units, divisions and subsidiaries as Additional Insureds, on a primary and non-contributory basis.
- (v) Waiver of Subrogation in favor of USS and its affiliates, including all units, divisions and subsidiaries.

If the Environmental Impairment Insurance is on a claims-made form, Contractor shall maintain continuous coverage or exercise an extended discovery period for a period of no less than five (5) years from the time that the work hereunder has been completed.

2. **Minimum Limits of Insurance** – Contractor and its Subcontractor(s) shall maintain limits *no less than*:

A. **Commercial General Liability**: Including Umbrella Liability Insurance, if necessary, limits shall be not less than \$5,000,000 each occurrence for personal injury and property damage; \$5,000,000 each occurrence and aggregate for products and completed operations; \$5,000,000 general aggregate. The limits and coverage requirements may be revised at the option of USS.

B. **Automobile Liability Insurance**: Including Umbrella Liability Insurance, if necessary, limits shall be not less than \$2,000,000 per accident for bodily injury and property damage, \$5,000,000 if hazardous materials or substances are to be transported.

C. **Workers' Compensation**: As required by the State or Commonwealth in which the work will be performed, and as required by any applicable Federal laws.

D. **Employer's Liability and/or Stop Gap Liability Coverage and/or Employer's Liability including Maritime Employer's Liability**: \$1,000,000 per accident, \$1,000,000 disease-policy limit, and \$1,000,000 disease each employee. (May include Umbrella coverage.)

E. **Errors and Omissions Professional Liability Insurance: (If applicable)** \$2,000,000 per loss; \$4,000,000 annual aggregate limit.

F. **Environmental Impairment Insurance: (If applicable)** \$5,000,000 combined single limit per loss. The limits and coverage requirements may be revised at the option of USS.

3. **Deductibles and Self-Insured Retentions** -- All insurance coverage carried by Contractor and its Subcontractor(s) shall extend to and protect USS, its subsidiaries and/or affiliates to the full amount of such coverage, and all deductibles and/or self-insured retentions (if any), including those relating to defense costs, are the sole responsibility of Contractor and its Subcontractor(s).

4. **Rating of Insurer** -- The Contractor and its Subcontractor(s) will only use insurance companies acceptable to USS and authorized to do business in the state or area in which the work hereunder is to be performed. Insurers must have a minimum rating of A-, Class VII, as evaluated by the most current A.M. Best rating guide. If the insurer has a rating less than an A-, Class VII, the Contractor must receive specific written approval from USS prior to proceeding.

5. **Other Insurance Provisions**

A. Each insurance policy required by this clause shall be endorsed to state that coverage shall not be suspended, voided, cancelled, reduced in coverage or in limits, or certificate holder deleted as additional insured except after thirty (30) days prior written notice by certified mail, return receipt requested, has been given to USS.

B. These insurance provisions are intended to be a separate and distinct obligation on the part of the Contractor. Therefore, these provisions shall be enforceable and Contractor and its Subcontractor(s) shall be bound thereby regardless of whether or not indemnity provisions are determined to be enforceable in the jurisdiction in which the work covered hereunder is performed.

C. The above-described insurance coverage to be provided by Contractor and its Subcontractor(s) hereunder will extend coverage to all work or services performed hereunder.

D. The obligation of the Contractor and its Subcontractor(s) to provide the insurance herein above specified shall not limit in any way the liability or obligations assumed by the Contractor and its Subcontractor(s) hereunder.

E. In the event Contractor and its Subcontractor(s), or its insurance carrier defaults on any obligations hereunder, Contractor and its Subcontractor(s) agree that they will be liable for all reasonable expenses and attorneys' fees incurred by USS to enforce the provisions hereunder.

6. **Evidence of Coverage**

A. Contractor shall furnish to USS copies of the endorsements effecting the coverage required by this specification. Additionally, *prior to the commencement of any work or services on USS's Premises*, Contractor shall furnish to USS Certificates of Insurance evidencing full compliance with the requirements herein. The Certificates of Insurance must show that the required insurance is in force, the amount of the carrier's liability thereunder, and must further provide that USS will be given thirty (30) days advance written notice of any cancellation or reduction in coverage or in limits, or deletion of the certificate holder herein as an Additional Insured under the policies. Contractor shall also carry such additional insurance as USS may specify in connection with the contractor's performance of its obligations under this agreement.

B. All Certificates of Insurance shall be in form and content acceptable to USS and shall be submitted to USS in a timely manner so as to confirm Contractor's full compliance with the insurance requirements stated hereunder.

C. Any failure on the part of USS to pursue or obtain the Certificates of Insurance required hereunder from Contractor and/or the failure of USS to point out any non-compliance of such Certificates of Insurance shall not constitute a waiver of any of the insurance requirements hereunder, nor relieve Contractor of any of its obligations or liabilities hereunder. Moreover, acceptance by USS of insurance submitted by the Contractor does not relieve or decrease in any manner the liability of the Contractor for performance hereunder. The Contractor is responsible for any losses, claims, and/or costs of any kind which their insurance does not cover.

D. In addition to its other remedies, USS may, at its sole option and without liability to Contractor, suspend the work and/or exclude Contractor from USS's premises until Contractor furnishes satisfactory evidence of its full compliance with the provisions hereunder.

7. **Subcontractors** -- *Prior to the commencement of any work or services on USS's Premises*, Contractor shall be responsible to obtain separate Certificates of Insurance from each Subcontractor. All coverages for Subcontractors shall be subject to all of the requirements stated herein.

COMMUNICATIONS
SEPTEMBER 16, 2013

1. Mountain-Buhl Public Schools, a thank you letter for the assistance at the baseball field.
2. Club Mesabi, a thank you for the support of the Great River Energy Mesabi Trail Tour.
3. Mountain Iron-Buhl Class of 2013 and the All Night Chemical Free Grad Party Committee, a thank you.

INDEPENDENT SCHOOL DISTRICT NO. 712
MOUNTAIN IRON-BUHL PUBLIC SCHOOLS

P. O. BOX 537, MOUNTAIN IRON, MN 55768-0537

(218) 735-8271 OFFICE | (218) 735-8244 FAX | WWW.MIB.K12.MN.US

Superintendent **John A. Klarich**

Principal
Merritt Elementary
John A. Klarich

Principal
High School
Angie Williams

Principal
Mesabi Academy
Derek J. Gabardi

August 28, 2013

Mr. Craig Wainio, City Administrator
City of Mt. Iron
8586 Enterprise Drive South
Mt. Iron, MN 55768

Dear Mr. Wainio:

On behalf of a grateful School District I would like to thank the City of Mt. Iron for helping us with the foul poles on the baseball field.

Once again, thank you for the assistance that the City provides the School District and your continued support of our school and community.

Sincerely,



John A. Klarich
I.S.D. #712 Superintendent of Schools

JAK/sp

SCHOOL BOARD

Charles Bainter | Larry Sokoloski | R. Michael Grahek | Steve Giorgi | Troy Martinson | Jeff Holmes | Betsy Olivanti

August 28, 2013

Craig Wainio
City of Mountain Iron
8586 Enterprise Drive South
Mountain Iron, MN 55768



Club Mesabi, Inc.
Great River Energy Mesabi Trail Tour
PO Box 139
Virginia, MN 55792
218-749-4331

Dear Craig,

A huge THANK YOU to you and the City of Mountain Iron for your wonderful continuing support of the Great River Energy Mesabi Trail Tour. Locomotive Park is the perfect location for a tour rest stop. August 3rd was an absolutely glorious day to ride a bicycle. Our 9th annual tour had almost 700 riders enjoying great weather, great food, great music, great company and a healthy dose of "Minnesota nice". We continue to receive high reviews from riders as many of them return year after year, making the tour a family tradition and inviting new family and friends to join us as well:

"The best bike ride in Minnesota, season after season."

"This is one of funnest and best organized rides I've been on. We'll be back!"

"Your volunteers were OUTSTANDING - always helpful, friendly and smiling. The picnic at the finish exceeded my expectations. Overall, you "hit it out of the park!"

"This was my first group ride, it'll be hard for any other future groups to compete with your Mesabi ride. Your volunteers were absolutely outstanding."

"Love this ride and the people who run it!"

"Excellent tour, extremely friendly volunteers, food was excellent - Thanks! This was our 8th year participating. Keep up the GREAT work!"

"You folks rock!" "Solid, I'd do it again!" "Great day for this old lady!"

It's only through support from venues and businesses like yours, that we are able to showcase our region and the Mesabi Trail in such a fun and exciting way. Thanks to your support, we have gained a reputation as a consistently high quality, well organized and extremely well received event.

2014 is going to be our 10th anniversary tour. We're already excited to start the planning of an extra special tour to celebrate this milestone. We haven't selected the route yet, but we already have communities clamoring to bring the Great River Energy Mesabi Trail Tour to their Mesabi Trail Town. It's so very gratifying to see the continuing and growing enthusiasm and support from our communities and new and recurring supporters like you!

Thanks again!!!

A handwritten signature in black ink, appearing to read "Ardy".

Ardy Nurmi-Wilberg
Club Mesabi Inc., Executive Director
Great River Energy Mesabi Trail Tour, Tour Director



The Mountain Iron-Buhl Class of 2013 and the All Night Chemical Free Grad Party Committee would like to thank you for your generous donation to the party. Without donations like yours we could not have such a successful and safe event for the graduating seniors. Thank you once again.

Jonathan
Brewer

Kentucky
Johnson

Joseph Kim
James
Kohler Lubes P...



William
Henderson

Haley
Schwabbe

William
Henderson

Primmer
Arie

William
Henderson

Cassie
Gnola

Brett
Derickson

Devin Rave
Ross Anderson

William
Henderson

William
Henderson

William
Henderson

Amber Wilder

Brett
McCauley
Aaron Johnson

Jaya Pinner

William
Henderson

William
Henderson

William
Henderson